

Description

The circuit provides a means to maintain minimal battery drain when placed into a standby mode while providing seamless switch over into high current mode. In the standby mode, the enable (EN) pin is pulled low. This disables the MIC2204 and the MIC94060. Power to the memory is provided only by the MIC5233 with very minimal current draw (around $28\mu\text{A}$ with a $10\mu\text{A}$ load). When enabled on, the

MIC2204 turns-on. The MIC94060 remains off for a time designated by the resistor and capacitor on the enable pin. This is to prevent the main supply load from momentarily dragging down the memory power. After the MIC94060 enable pin charges up, it turns-on providing a low resistance path for the MIC2204 to maintain both memory and main power.

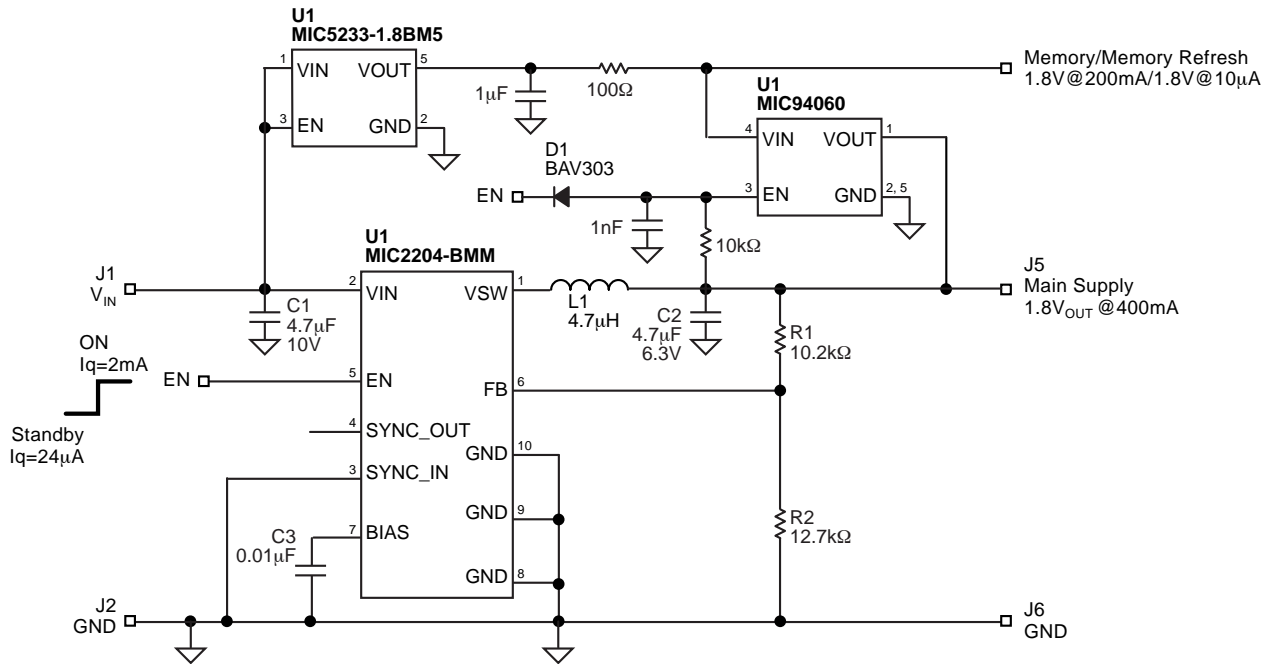

Power Supply Circuit with Memory Refresh

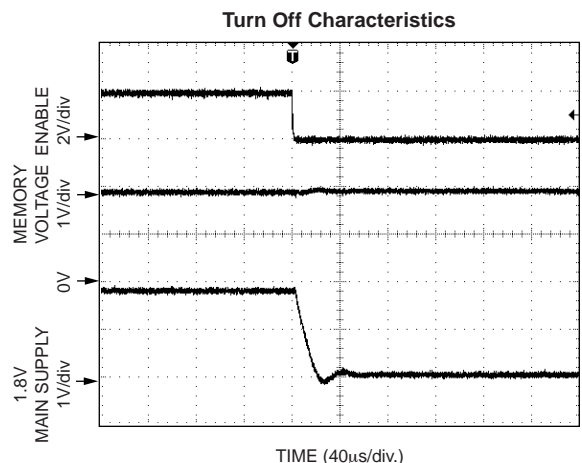
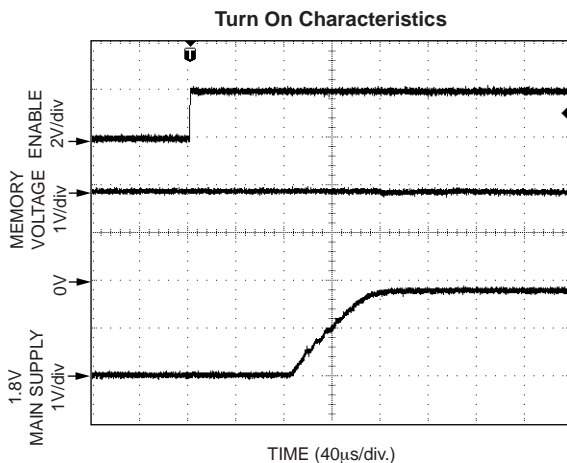

Bill of Materials

Item	Part Number	Manufacturer	Description	Qty.
C1, C2	LMK212BJ475MG	Taiyo Yuden ⁽¹⁾	4.7 μ F/6.3V	2
C3	VJ0603Y103KMXX	Vitramon ⁽²⁾	0.01 μ F/25V	1
D1	BAV303	Vishay ⁽³⁾	250mA General Purpose Diode	1
L1	LQH32CN4R7M11	Murata ⁽⁴⁾	4.7 μ H	1
R1	CRCW06031022FRT1	Vishay ⁽³⁾	10.2k Ω , 1/16W, 1%, Size 0603	1
R2	CRCW06031272FRT1	Vishay ⁽¹⁾	12.7k Ω , 1/16W, 1%, Size 0603	1
U1	MIC2204BMM	Micrel, Inc. ⁽⁵⁾	High Efficiency 2MHz Synchronous Buck Converter	1
U2	MIC94060	Micrel, Inc. ⁽⁵⁾	100M Ω SC-70 Smart Load Switch	1
U3	MIC5233-1.8BM5	Micrel, Inc. ⁽⁵⁾	Low IQ μ Cap LDO Regulator	1

1. Taiyo Yuden: www.taiyo-yuden.com

2. Vitramon: www.vishay.com

3. Vishay: www.vishay.com

4. Murata: www.murata.com

5. **Micrel, Inc.:** www.micrel.com

MICREL, INC. 1849 FORTUNE DRIVE SAN JOSE, CA 95131 USA

TEL + 1 (408) 944-0800 FAX + 1 (408) 944-0970 WEB <http://www.micrel.com>

The information furnished by Micrel in this datasheet is believed to be accurate and reliable. However, no responsibility is assumed by Micrel for its use. Micrel reserves the right to change circuitry and specifications at any time without notification to the customer.

Micrel Products are not designed or authorized for use as components in life support appliances, devices or systems where malfunction of a product can reasonably be expected to result in personal injury. Life support devices or systems are devices or systems that (a) are intended for surgical implant into the body or (b) support or sustain life, and whose failure to perform can be reasonably expected to result in a significant injury to the user. A Purchaser's use or sale of Micrel Products for use in life support appliances, devices or systems is at Purchaser's own risk and Purchaser agrees to fully indemnify Micrel for any damages resulting from such use or sale.

© 2003 Micrel, Incorporated.