

## Introduction

With duty cycle limitations of typical step-up switching regulators it is very difficult to drive 20 white LEDs in a single series string using a simple inductor. The difficulty in driving 20 white LEDs in a single series string is with the maximum duty cycle specification of the particular step-up switching regulator being used, with 20 white LEDs the resulting duty cycle may exceed the maximum duty cycle capability of the particular step-up switching regulator. The circuit in Figure 1 illustrates how a typical step-up switching regulator (MIC2291) can drive 20 white LEDs without violating its maximum duty cycle specification

## Circuit Description

In Figure 1 the first white LED string, D1→D5, with the R1 resistor is connected to the feedback voltage pin of the MIC2291. The R1 resistor sets the current that will flow through the other strings of white LEDs. The current matching to the other white LED strings of the transistor array is performed by the simple current mirror circuit configuration of the PNP or PMOS transistor array.

With each transistor in the array having the same  $V_{BE}$  (base-to-emitter voltage) or  $V_{GS}$  (gate-to-source voltage) voltage their collector (PNP) or drain (PMOS) bias currents will be closely matched. The \*R resistors are optional resistors that minimize the impact of the Early effect, where differences in  $V_{CE}$  (collector-to-emitter) or  $V_{DS}$  (drain-to-source) voltages may result in mismatched bias currents through each member of the transistor array.

## Bill of Material

Ref Des	Part Number	Description	Manufacturer
C1	C2012X5R1A225K	2.2 $\mu$ F 10V Ceramic Capacitor, Size 0805	TDK
	0805ZD225KAT	2.2 $\mu$ F 10V Ceramic Capacitor, Size 0805	AVX
C2	C2012X5R1E225K	2.2 $\mu$ F 25V Ceramic Capacitor, Size 0805	TDK
	12063D225KAT	2.2 $\mu$ F 25V Ceramic Capacitor, Size 1206	AVX
D	MBRM140	1A 40V Schottky Diode	On Semiconductor
	SS14	1A 40V Schottky Diode	Vishay
D1 ... D20	TLMW3101	High Intensity SMD LED	Vishay
L	VLF4012AT-100MR79	10 $\mu$ H 800mA Inductor	TDK
	SD3812-100	10 $\mu$ H 778mA Inductor	Cooper Bussmann
R1	CRCW06031R00FRT1	1 $\Omega$ Resistor, Size 0603	Vishay
	THAT320	Quad Low-Noise PNP Transistor Array	That Corporation
	ALD1107	Quad P-Channel Matched Pair MOSFET Array	Advanced Linear Devices
U1	MIC2291-34BML	MLF™ 1.2MHz PWM Step-Up Converter	Micrel

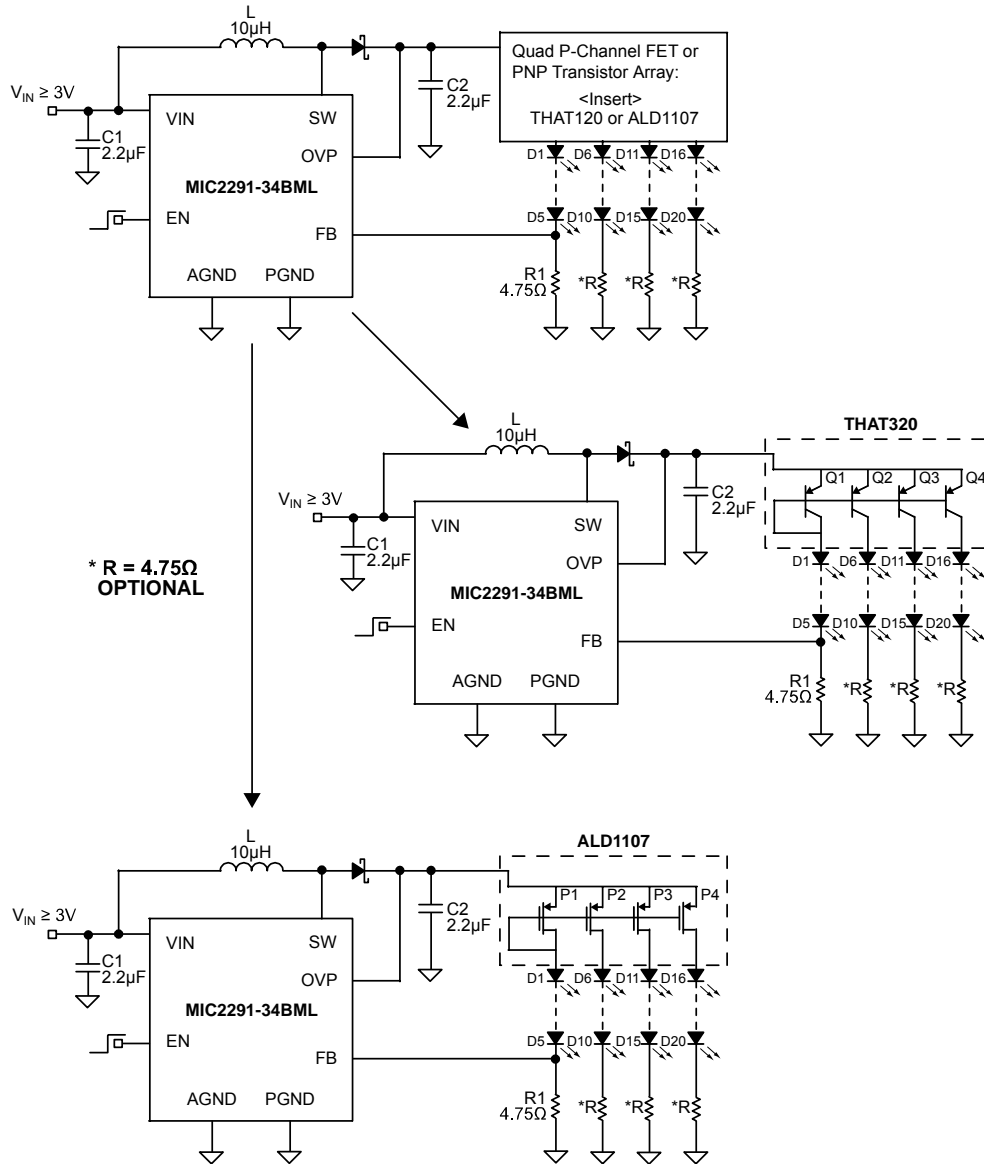

Figure 1

**MICREL, INC. 2180 FORTUNE DRIVE SAN JOSE, CA 95131 USA**  
 TEL +1 (408) 944-0800 FAX +1 (408) 474-1000 WEB <http://www.micrel.com>

This information furnished by Micrel in this data sheet is believed to be accurate and reliable. However no responsibility is assumed by Micrel for its use. Micrel reserves the right to change circuitry and specifications at any time without notification to the customer.

Micrel Products are not designed or authorized for use as components in life support appliances, devices or systems where malfunction of a product can reasonably be expected to result in personal injury. Life support devices or systems are devices or systems that (a) are intended for surgical implant into the body or (b) support or sustain life, and whose failure to perform can be reasonably expected to result in a significant injury to the user. A Purchaser's use or sale of Micrel Products for use in life support appliances, devices or systems is a Purchaser's own risk and Purchaser agrees to fully indemnify Micrel for any damages resulting from such use or sale.

© 2005 Micrel Incorporated