



## Application Hint 70

### MIC2193 3.3V to 2.5V/5A with Ceramic Cout Application Circuit

By Steven Chenetz

#### General Description

The MIC2193 is a 400kHz Synchronous Buck controller that uses a P-channel high-side FET. It has the advantage of running at 100% duty cycle (high-side Fet always on), which is useful for applications where the input and output voltage are close together. This application circuit converts a 3.3V +/-10% input to a 2.5V/5A output. The circuit uses ceramic capacitors on both the input and output.

#### Efficiency's effect on duty cycle

The relationship between  $V_{in}$ ,  $V_{out}$  and duty cycle ( $D$ ) in an ideal buck converter (100% efficiency) is:

$$D = \frac{V_{out}}{V_{in}}$$

Losses in the circuit force the duty cycle to increase to maintain output regulation. The duty cycle equation becomes:

$$D = \frac{V_{out}}{\eta \times V_{in}} \quad \text{where } \eta = \text{efficiency}$$

For a 3.3V input with +/-10% regulation and 88% efficiency, the operating duty cycle is:

$$D = \frac{2.5V}{0.88 \times 2.97V} = 0.957$$

Although some N-channel Buck controllers can operate in the 95% duty cycle range, there is no margin to increase the duty cycle when responding to output current transients. For this case, a P-channel controller is a better option.

The schematic and BOM are shown below in Figures 1 and 2:

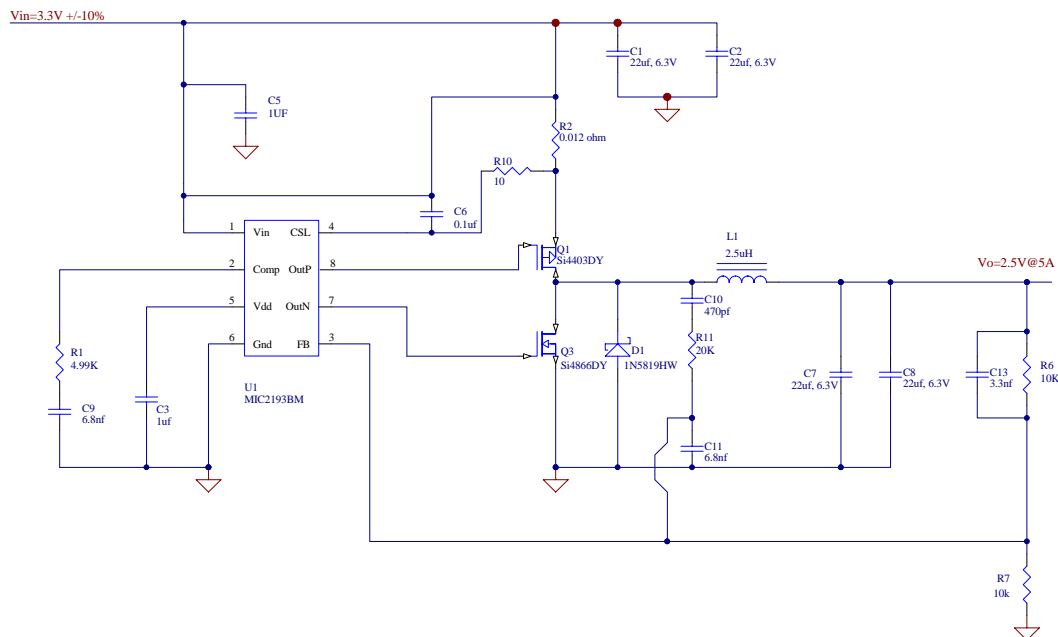

Figure 1

### Bill of Materials

Quant	Part Description	Ref Des	Vendor	Vendor P/N
1	Buck controller	U1	Micrel.Inc	MIC2193BM
1	MOSFET	Q1	Vishay/Siliconix	Si4403DY
			Fairchild	FDS6375
1	MOSFET	Q3	Vishay/Siliconix	Si4866DY
			Fairchild	NDS8425
1	1A, 30V Schottky diode	D1	Diodes Inc	1N5819HW
1	2.5uH, 6A inductor	L1	Sumida	CDRH104R-2R5
			Cooper Electronics	CD1-2R5
4	22uf, 6.3V	C1, C2, C7, C8	TDK	C3225X5R0J226M
2	6.8nf/25V ceramic cap	C9, C11	Vishay	VJ0805Y682KXXAT
2	1uF/25V, ceramic cap	C3, C5	Vishay	VJ0805S105KXJAT
1	0.1uf/25V, X7R ceramic cap	C6	Vishay	VJ0805Y104KXXAT
1	3.3nf, X7R ceramic cap	C13	Vishay	VJ0805Y332KXXAT
1	470pf ceramic cap	C10	Vishay	VJ0805Y471KXXAT
1	4.99K, 0805, 1/10W, 1%	R1	Vishay	VJ08054991FRT1
1	20K, 0805, 1/10W, 1%	R11	Vishay	VJ08052002FRT1
1	0.012 ohms (2010 size), 1%	R2	Vishay	WSL-2010-R012-F
1	10K (0805 size), 1%	R6	Vishay	VJ08051002FRT1
1	10K (0805 size), 1%	R7	Vishay	VJ08051002FRT1
1	10 ohms (0805 size), 1%	R10	Vishay	VJ080510R0FRT1

Notes:

1. Micrel Semiconductor Tel: 408-944-0800
2. Diodes Inc. Tel: 805-446-4800
3. TDK Tel: 847-803-6100
4. Sumida Tel: 408-982-9660
5. Vishay Tel: 402-644-4218
6. Cooper ET Tel: 561-752-5000
7. Fairchild Tel: 972-910-8000

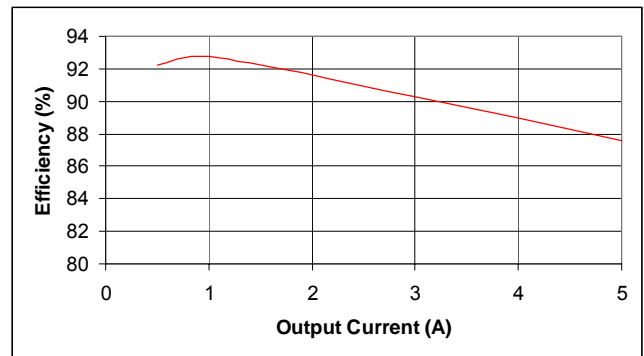

Efficiency for 3.3Vin to 2.5Vo

---

**MICREL, INC. 2180 FORTUNE DRIVE SAN JOSE, CA 95131 USA**  
TEL +1 (408) 944-0800 FAX +1 (408) 474-1000 WEB <http://www.micrel.com>

The information furnished by Micrel in this data sheet is believed to be accurate and reliable. However, no responsibility is assumed by Micrel for its use. Micrel reserves the right to change circuitry and specifications at any time without notification to the customer.

Micrel Products are not designed or authorized for use as components in life support appliances, devices or systems where malfunction of a product can reasonably be expected to result in personal injury. Life support devices or systems are devices or systems that (a) are intended for surgical implant into the body or (b) support or sustain life, and whose failure to perform can be reasonably expected to result in a significant injury to the user. A Purchaser's use or sale of Micrel Products for use in life support appliances, devices or systems is a Purchaser's own risk and Purchaser agrees to fully indemnify Micrel for any damages resulting from such use or sale.

© 2006 Micrel, Incorporated.