

Introduction

Micrel's MIC457x family of BiCMOS simple buck voltage regulators feature faster rise/fall time, faster response to fault conditions, and improved efficiency at light loads.

Description

The MIC457x switching regulator is basically a PWM (pulse width modulation) controller IC with a fixed gain error amplifier, a 200kHz oscillator, and internal compensation network. The non-inverting side of the error amplifier is tied to a 1.23V bandgap reference.

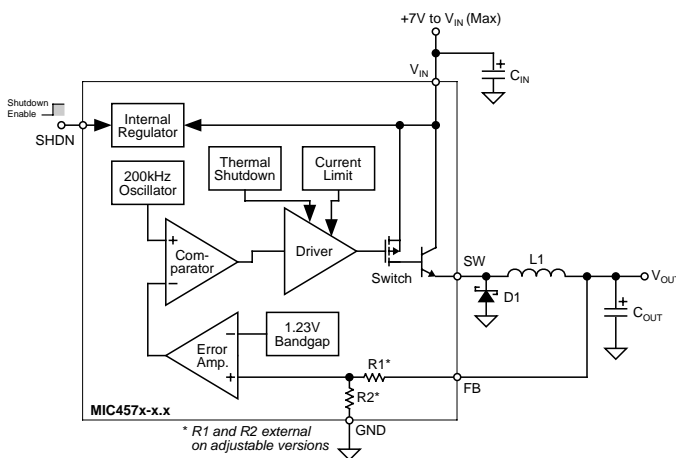

Figure 1. Block Diagram (Fixed Version)

Buck Regulator Design Procedure

Select the MIC4574 (0.5A), MIC4575 (1A), or MIC4576 (3A) based on the required output current. If higher current rated regulators are chosen for low current applications, make sure the current limit range is appropriate for that application.

Output Voltage

For fixed output voltages, 3.3V or 5.0V versions are available. The output voltage of the adjustable regulators is configured using an external resistive divider.

$$V_{OUT} = 1.23V \left(1 + \frac{R2}{R1} \right)$$

For best performance, R1 should be between 1k and 10k.

Inductor Selection Criteria

The following criteria is used for inductor selection:

- Mode of operation (continuous or discontinuous).
- Peak inductor current
- Volt-seconds (V·s) applied to the inductor

Definitions

Critical Inductance Condition The critical inductance condition is when the current through the inductor decays to zero just prior to the next "on" time of the regulator switch. This occurs at the boundary between continuous and discontinuous operation.

Discontinuous Operation Discontinuous operation occurs when, for any condition of input voltage or output current, the inductor current decays to zero before the next "on" time of the regulator switch.

Continuous Operation Continuous operation occurs when, for any condition of input voltage or output current, the inductor current does not decay to zero before the next "on" time of the regulator switch.

Continuous Conduction Operation

Critical Inductance

Compute the value of critical inductance required for the application at the worst case combination of input voltage and output load current. This will be the minimum value of inductance that will guarantee continuous conduction operation over all input voltage and output load conditions.

At the critical inductance condition, the peak inductor current is twice the average current. The average current is the current delivered to the load. The peak current at the critical inductance condition is:

$$(1) \quad I_{PEAK} = \frac{D (V_{IN} - V_{OUT})}{L f_S}$$

Where:

D = duty cycle

D = switch on time/switch cycle time, T_{ON} / τ

τ = switch cycle time, $1 / f_S$, (s)

V_{IN} = input (supply) voltage (V)

V_{OUT} = regulator output voltage (V)

L = inductance of filter inductor (H)

f_S = switching frequency (Hz)

The input power will be assumed to be equal to the output power.

$$(2) \quad E_{FF} V_{IN} I_L D = \frac{V_{OUT}^2}{R_{LOAD}}$$

Where:

E_{FF} = estimated efficiency
reasonable initial estimate 80% (0.8)

R_{LOAD} = load resistance (Ω)

and,

$$(3) \quad L_{\text{CRITICAL}} = \frac{R_{\text{LOAD}} (1-D)}{2 f_S}$$

Duty Cycle

Compute the duty cycle required at the maximum required input voltage and minimum load current. If you cannot guarantee a minimum load current, an additional resistive load may be required at the regulator output.

$$D_{\text{MIN}} = \frac{V_{\text{OUT}}}{V_{\text{IN(max)}}}$$

Use this value of D_{MIN} and the minimum value of R_{LOAD} in equation (3) to determine the value of critical inductance. This is the minimum value of inductance required. Changing the minimum load and/or the maximum input voltage requirement changes the minimum required critical inductance.

The value of inductance can be chosen to allow the regulator to operate in discontinuous mode under certain conditions. Discontinuous mode typically occurs at maximum input and minimum load current. In many cases this may not present a problem, however, it should be verified that operation in discontinuous mode still allows the circuit to satisfy the load regulation requirement.

Maximum V·s

Compute the maximum volt-microseconds applied to the inductor:

$$V \cdot s = (V_{\text{IN}} - V_{\text{OUT}}) \frac{V_{\text{OUT}}}{V_{\text{IN(max)}}} \tau$$

Inductor Peak Current

Compute the peak current through the inductor. This is the sum of the maximum load current and peak ripple current through the inductor.

$$I_{\text{PEAK}} = \frac{1}{2} \left(\frac{V_{\text{IN(max)}} - V_{\text{OUT}}}{L} \right) \tau \frac{V_{\text{OUT}}}{V_{\text{IN(max)}}} + \frac{V_{\text{OUT}}}{R_{\text{LOAD}}}$$

Inductor Selection

Refer to the "Inductor Selection and Cross Reference" table to select the appropriate inductor for your application. The selection should satisfy the following:

Inductance > Calculated Critical Inductance

Volt-second Capability > Calculated V·μs
(if applicable)

$I_{\text{DC}} > \text{Calculated } I_{\text{PEAK}} \text{ Current} \times 0.85$

Output Capacitor Selection

For stable operation, the output capacitor must satisfy the following:

$$C_{\text{OUT}} \geq 13300 \left(\frac{V_{\text{IN(max)}}}{V_{\text{OUT}} L} \right)$$

Where:

C_{OUT} = output capacitance (μF)

L = inductance (μH)

This guarantees that the dominant pole pair of the LC filter does not occur at a frequency that is too high for the regulator's internal loop compensation circuitry. This computation may result in a capacitor value that is too small to provide adequate peak-to-peak output ripple reduction.

Peak-to-peak ripple voltage is a function of the capacitor value and type. A low ESR/ESL (equivalent series resistance/equivalent series inductance) capacitor should be used for lower ripple voltage. (Standard capacitors may be paralleled to reduce the effective ESR/ESL value.) Low ESR electrolytic capacitors are available from Panasonic, Nichicon, and United Chemicon.

Maximum peak-to-peak ripple voltage (assuming no ESR or ESL in the filter capacitor) can be estimated as follows:

$$V_{\text{P-P}} = \frac{1}{C} \times \left(\frac{V_{\text{IN(max)}} - V_{\text{OUT}}}{L} \right) \times \frac{1}{2} \times \frac{V_{\text{OUT}}^2}{V_{\text{IN}}^2} \tau^2$$

Input Capacitor Selection

The input bypass capacitor must be at least 47μF to maintain stability. Low ESR capacitors are recommended. If the operating temperature range is below -25°C, the value of this capacitor should be increased. Adding a ceramic or solid tantalum capacitor near the input pin will also increase regulator stability at low temperatures. The capacitor's ripple current rating should be more than the ripple component of the inductor current:

$$I_{\text{RIPPLE}} = \frac{\tau}{2} \left(\frac{V_{\text{IN(max)}} - V_{\text{OUT}}}{L} \right)$$

Catch Diode Selection

Although either a Schottky or a fast recovery diode can be used, a Schottky diode will provide the best performance because its lower voltage drop and faster switching speed will result in higher efficiency. Fast recovery diodes with abrupt turn-off characteristics may cause EMI problems and/or instabilities.

The reverse voltage rating of the catch diode should be at least 1.25 × the maximum input voltage.

Standard 1N400x series diodes should not be used. The reverse recovery time of this type of diode is excessive which will cause additional noise and heat dissipation in the diode and the regulator's internal power switch.

Typical Applications

Fixed 3.3V Buck Regulator

Figure 2 shows a 3.3V buck regulator using inexpensive standard components.

The high efficiency (~80%) and low form factor afforded by the use of a new TO-263 surface mount package makes this ideal for battery operated designs.

If lower ripple voltage is desired, the standard 220 μ F capacitor can be replaced with a standard 330 μ F. For lower ripple at a small size, an Oscon 105A220M capacitor (220 μ F, 35m Ω ESR) can be used.

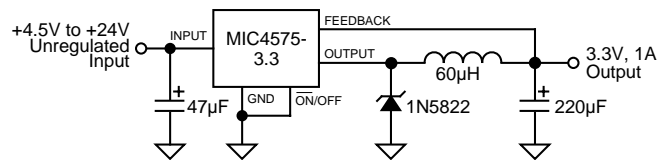

Figure 2. 3.3V Buck Regulator

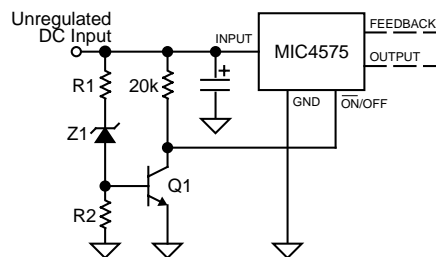

Figure 3. Undervoltage Lockout

Inductor Selection and Cross Reference

	Renco Part ¹ Part No.	I _{PC} (A)	V·μs (V·μs)	L (μH)	Description	
	RL5341-20-1	1	43	20	powdered iron	
	RL5341-48-1	1	51	48		
	RL5341-68-1	1	155	68		
	RL5341-100-1	1	200	100		
	RL5341-150-1	1	330	150		
	RL5341-220-1	1	400	220		
	RL5341-330-1	1	680	330		
	RL5341-470-1	1	796	470		
	RL5341-680-1	1	1500	680		
RL5341-1000-1	1	2000	1000			
	RL5342-20-1	1	26	20	moly permalloy	
	RL5342-48-1	1	60	48		
	RL5342-68	1	88	68		
	RL5342-100-1	1	116	100		
	RL5342-150-1	1	193	150		
	RL5342-220-1	1	285	220		
	RL5342-330-1	1	400	470		
	RL5342-470-1	1	604	470		
	RL5342-680-1	1	888	680		
RL5342-1000-1	1	1200	1000			
	RL5341-20-3	3	140	20	powdered iron	
	RL5341-48-3	3	257	48		
	RL5341-68-3	3	471	68		
	RL5341-100-3	3	640	100		
	RL5341-150-3	3	885	150		
	RL5341-220-3	3	1272	220		
	RL5341-330-3	3	2155	330		
	RL5341-470-3	3	3221	470		
	RL5341-680-3	3	4784	680		
RL5341-1000-3	3	6000	1000			
	RL5342-20-3	3	81	20	moly permalloy	
	RL5342-48-3	3	177	48		
	RL5342-68-3	3	273	68		
	RL5342-100-3	3	392	100		
	RL5342-150-3	3	591	150		
	RL5342-220-3	3	872	220		
	RL5342-330-3	3	1202	470		
	RL5342-470-3	3	1946	470		
	RL5342-680-3	3	2837	680		
RL5342-1000-3	3	3900	1000			

1. Renco Electronics Inc., Deer Park, New York; tel: (516) 586-5566

MICREL INC. 1849 FORTUNE DRIVE SAN JOSE, CA 95131 USA

TEL + 1 (408) 944-0800 FAX + 1 (408) 944-0970 WEB <http://www.micrel.com>

This information is believed to be accurate and reliable, however no responsibility is assumed by Micrel for its use nor for any infringement of patents or other rights of third parties resulting from its use. No license is granted by implication or otherwise under any patent or patent right of Micrel Inc.

© March 2001 Micrel Incorporated