

### Introduction

Photoflash and strobe devices operate by discharging a high-voltage capacitor into a bulb. Operation of these circuits from a battery or other low-voltage source requires a step-up dc-dc converter to boost up to a high voltage, typically 300V. One way to generate this voltage is by using a flyback converter topology. This circuit provides a simple and reliable way of charging a high-voltage capacitor. It provides safety isolation via the flyback transformer. The circuit uses a minimum number of components to reduce board space and increase reliability.

### Theory

The flyback converter performs two functions (Figure 1). The converter must boost the low-voltage input as well as provide isolation between input (battery) and output (high voltage). The main circuit components are the power transformer, output diode, output capacitor and MIC3172 controller chip. The MIC3172 packages the switching transistor, voltage regulation, and control logic into one IC, which simplifies the circuit.

Energy is stored in the transformer when the internal transistor of the MIC3172 turns on, allowing current to flow through the transformer primary. When the transistor turns off, energy stored in the transformer flows through the output rectifying

diode into the capacitor. The voltage across the capacitor is increased with each switching cycle until it reaches the preset voltage. This preset voltage is determined by the resistive divider (R1, R2, and R3) and internal 1.24V reference of the MIC3172. The output voltage set point is:

$$V_{OUT} = V_{REF} \left( 1 + \frac{R1 + R2}{R3} \right)$$

Once this voltage is reached, the MIC3172 stops switching. Since energy leakage in the output components causes the capacitor to discharge over time, the MIC3172 provides occasional pulses of energy to keep the capacitor fully charged. When the output capacitor is discharged into the bulb the charging process is repeated.

### Circuit Description and Analysis

The MIC3172 simplified block diagram is shown in Figure 2. It contains a switching transistor, current-limit circuit, enable input, and error amplifier for voltage regulation. The switching frequency of the MIC3172 is 100kHz. When the output voltage is less than the preset voltage the error amplifier output will be high, causing the controller to run the flyback converter at maximum power. The current-limit circuit in the MIC3172 and the input voltage limits the output power. As the

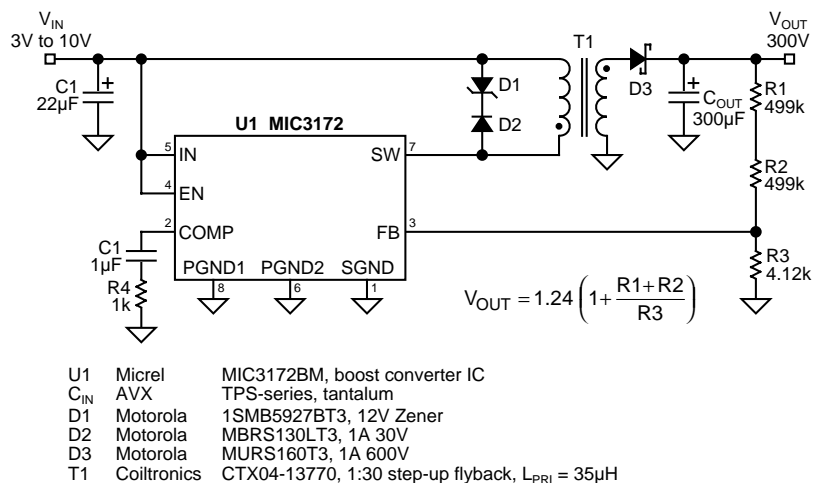

Figure 1. Flyback Converter

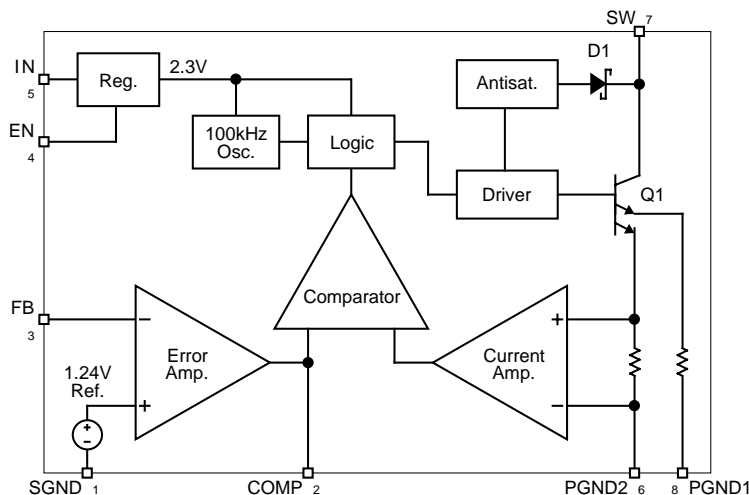

Figure 2. MIC3172 Block Diagram

output reaches its regulated voltage, the error amplifier voltage level will decrease to maintain the preset output voltage.

For this application, the flyback converter will operate in the continuous conduction mode. Not all the energy in the transformer will be delivered to the load for each switching cycle. When the output voltage reaches the preset limit the converter will operate in a pulse-skipping mode to overcome any output losses. During this part of the converter operation, the flyback will be operating in the discontinuous mode. During discontinuous operation all energy stored in the flyback transformer is transferred to the load. The compensating resistor and capacitor (R4 and C1) is designed to provide stable operation in discontinuous mode.

Diodes D1 and D2 are used to clamp any voltage spikes on the collector of the MIC3172 switch node caused by the leakage inductance in the transformer. When the internal transistor of the MIC3172 turns off, the voltage across the primary of the transformer is approximately equal to the output voltage divided by the turns ratio. The voltage on the transistor collector node ( $V_{SW}$ ) is equal to the reflected voltage plus the input voltage plus the voltage spike caused by the leakage energy in the transformer.

$$V_{SW} = \frac{V_{OUT}}{N} + V_{IN} + V_{leakage}$$

The maximum voltage at this node must be less than 65V.

The Zener diode voltage is set greater than the maximum reflected voltage at the transformer primary. For the example in Figure 1, the reflected voltage is 10V. The Zener is selected to be 12V (approximately 20% greater than the reflected voltage). The maximum reverse voltage across D2 is equal to the maximum input voltage. This diode must be an ultrafast or Schottky diode to prevent excessive diode losses.

### Capacitor Charging Time

The energy stored in the output capacitor is  $0.5 \cdot C \cdot V^2$ .

The output power required by the flyback converter to charge the capacitor in a period of time is:

$$P_{\text{capacitor}} = \left( \frac{0.5 \cdot C \cdot V^2}{t} \right)$$

The approximate charge time for the converter circuit is:

$$t_{\text{charge}} = \frac{C_{OUT} \cdot V_{OUT}^2}{2 \cdot V_{IN} \cdot I_{PK} \cdot D \cdot \text{efficiency}}$$

Where:

$I_{PK}$  = MIC3172 controller peak current-limit level (typically 1.8A)

D = maximum duty cycle (approximately 0.6 at current limit)

efficiency = flyback converter efficiency (0.5)

Charging a 300 $\mu$ F capacitor to 300V from a 5V input requires:

$$t = \frac{300\mu\text{F} \cdot 300\text{V}^2}{2 \cdot 5\text{V} \cdot 1.8\text{A} \cdot 0.6 \cdot 0.5} = 5\text{s}$$

### Safety and Protection

For the circuit above, the output voltage presents a **potentially lethal voltage**. At 300V, the charge on the output capacitor is 27 joules, which is more than enough to ruin an otherwise good day. When laying out the circuit, make sure there is adequate spacing between the high-voltage and low-voltage sections. The power transformer, such as the Coiltronics CTX04-13770, must have the proper spacing and insulation between the high-voltage secondary and the low-voltage primary.

Two resistors (R1 and R2) are used in the upper section of the output voltage to reduce their voltage stress, since commonly available resistors are only rated to 300V—too close to their limit for reliable long-term operation. If R1 or R2 should open up or if R3 is shorted, the converter will run open loop at its maximum duty cycle. This will boost the voltage far above the preset limit and cause the output capacitor to vent.

With all high-voltage and high-energy circuits, it is a good idea to include an overvoltage circuit for protection. The circuit shown in Figure 3 will provide overvoltage protection with a minimum number of components. Make sure the resistor divider for the overvoltage circuit is separate from the voltage regulation resistor divider. Set the overvoltage level 15% higher than the output voltage setting and make sure it does not exceed the output capacitor voltage rating.

**Decreasing Charging Time**

Faster charge times are possible by using the MIC2171 switching regulator chip. It is similar to the MIC3172 but has twice the peak current limit. The MIC2171 comes in a TO-220 through-hole or TO-263 surface-mount package. The circuit is shown in Figure 4.

Calculate the charge time using the MIC2171:

$$t_{\text{charge}} = \frac{C_{\text{OUT}} \cdot V_{\text{OUT}}^2}{2 \cdot V_{\text{IN}} \cdot I_{\text{PK}} \cdot D \cdot \text{efficiency}}$$

Where:

$I_{\text{PK}}$  = MIC2171 controller peak current-limit level (typically 3.6A)

$D$  = maximum duty cycle (approximately 0.6 at current limit)

efficiency = flyback converter efficiency (0.5)

Charging a 300μF capacitor up to 300V from a 5V input using the MIC2171 would require:

$$t_{\text{charge}} = \frac{300\mu\text{F} \cdot 300\text{V}^2}{2 \cdot 5\text{V} \cdot 3.6\text{A} \cdot 0.6 \cdot 0.5} = 2.5\text{s}$$

**Conclusion**

The MIC3172 and MIC2171 provide an integrated package that reduces the component count and complexity of the photo flash charger circuit. The ICs include the switching transistor, current limit, enable, and PWM control functions in a single package. A custom transformer has already been designed which simplified the design and implementation of this circuit.

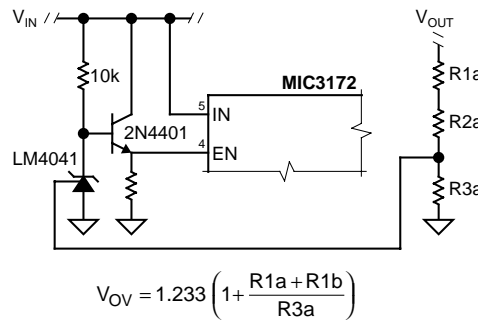

**Figure 3. Overvoltage Protection Circuit**

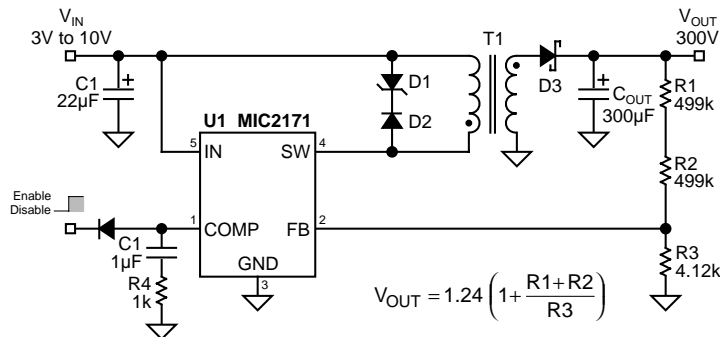

U1	Micrel	MIC2171BU, boost converter IC
C <sub>IN</sub>	AVX	TPS-series, tantalum
D1	Motorola	1SMB5927BT3, 12V Zener
D2	Motorola	MBRS130T3, 1A 30V
D3	Motorola	MURS160T3, 1A 600V
T1	Coiltronics	CTX04-13770, 1:30 step-up flyback, L <sub>PR1</sub> = 35μH

**Figure 4. MIC2172 Flyback Converter**

---

**MICREL INC. 1849 FORTUNE DRIVE SAN JOSE, CA 95131 USA**

TEL + 1 (408) 944-0800 FAX + 1 (408) 944-0970 WEB <http://www.micrel.com>

This information is believed to be accurate and reliable, however no responsibility is assumed by Micrel for its use nor for any infringement of patents or other rights of third parties resulting from its use. No license is granted by implication or otherwise under any patent or patent right of Micrel Inc.

© 1998 Micrel Incorporated