

General Description

Next generation gateway solutions for the small office and home office require connectivity between multiple local computing devices as well as to the WAN. There are several challenges that arise when designing such a system, especially LAN/WAN separation, WAN uplink overloading, security integrity, and MAC ID cloning.

The Micrel KS8995M offers two solutions for these issues that allow the designer to use the KS8995M for both the LAN and WAN connections, reducing BOM costs. The first solution uses the dual MII feature on the KS8995M. The second solution uses the new tag-based VLAN support.

This application note describes how to use the KS8995M's tag-based VLAN features in a gateway solution.

Scenario

In a small office, there are three computers connected to a gateway implemented with the KS8995M and a microprocessor, as shown in Figure 1.

Ports 1, 2, and 3 on the KS8995M are connected to the three computers. Port 4 serves as the WAN port. Port 5 is connected to the microprocessor through the KS8995M switch MII interface.

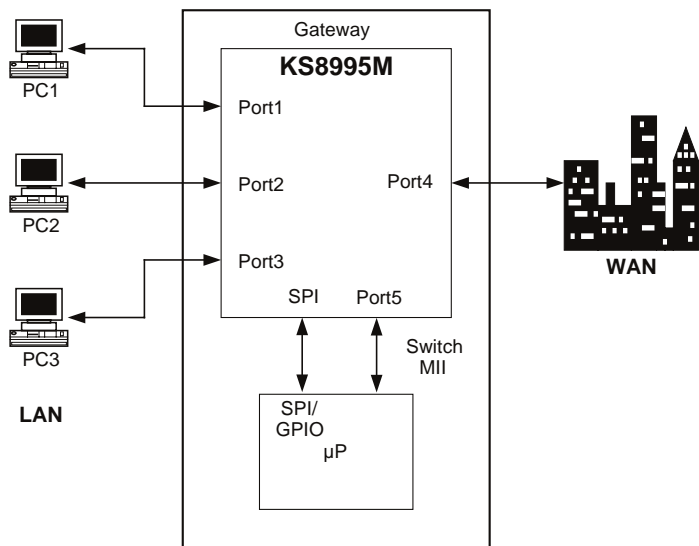

Figure 1. KS8995M Gateway Configuration

The LAN/WAN separation and WAN uplink overloading issues are resolved by configuring two different VLANs. VLAN 1 includes the LAN ports and the microprocessor port. VLAN 2 includes the microprocessor port and the WAN port.

The microprocessor serves as the gatekeeper. All LAN traffic from ports 1, 2, and 3 must pass through the microprocessor to reach the WAN. All WAN traffic must pass through the microprocessor to reach ports 1, 2, and 3.

Port	VLAN Membership
1	VLAN 1
2	VLAN 1
3	VLAN 1
4	VLAN 2
5	VLAN 1, VLAN 2

Table 1. VLAN Membership

This VLAN configuration also solves security integrity issues. With port-based VLAN, broadcast and multicast packets from the processor port are forwarded to both LAN and WAN ports; however, this violates the KS8995M's LAN/WAN separation requirements. With the new tag-based VLAN feature, multicast and broadcast packets received in a VLAN are only forwarded to the ports that are members. This ensures that LAN ARP packets are not forwarded directly to the WAN, and that multicast traffic does not overburden the WAN port.

The MAC cloning issue is also solved by this VLAN configuration. In our scenario, for instance, assign ports 1, 2, 3, and 5 the source MAC addresses of 1, 2, 3, and 5, respectively. The processor replaces all of these source MAC addresses with MAC address 1 in packets destined for the WAN. In this way, a single source MAC address is presented to the WAN. This is valuable if the ISP requires the user to be locked to a single MAC address. For packets that are from the WAN destined for a port on the LAN, a switch would normally have address migration problems since the processor port and port 1 are both using a MAC address of 1. However, with the tag-based VLAN in place, all packets from the WAN with a destination MAC address of 1 will be sent to the microprocessor on port 5. The microprocessor uses the packet's higher layer information to determine to which LAN port to forward the packet. It also replaces the packet's source address with the true microprocessor MAC address of 5, thus eliminating any confusion the switch would have with two ports using the same MAC address.

Tag-Based VLAN Configuration via SPI Interface

The KS8995M for tag-based VLAN support can also be configured via the SPI interface that is connected to the microprocessor. The following procedure gives the steps for this type of configuration:

1. Enable the KS8995M's 802.1Q VLAN support.
 - a. Wr 5 80
2. Assign ports 1, 2, 3, and 5 to VLAN 1. This allows these ports to communicate with one another, while isolating ports 1, 2, and 3 from port 4.
 - a. Uvtab 0 vid = 1 fid = 1 mbr = 17
3. Assign port 5 and the WAN port to VLAN 2. This allows ports 4 and 5 to communicate with one another, while isolating port 4 from ports 1, 2, and 3.
 - a. Uvtab 1 vid = 2 fid = 2 mbr = 18
4. Configure ports 1, 2, and 3 with a default VLAN ID of 1. The KS8995M inserts the ingress port's default VLAN ID on untagged packets or packets with a null VLAN ID for internal switch use. All other packets received on ports 1, 2, and 3 are tagged with a VLAN ID of 1.
 - a. Wr 14 01
 - b. Wr 24 01
 - c. Wr 34 01
5. Configure Ingress VLAN filtering on ports 1, 2, and 3. This enables the KS8995M to discard packets with an invalid VLAN ID.
 - a. Wr 12 46
 - b. Wr 22 46
 - c. Wr 32 46
6. Configure port 4, the WAN port, with a default VLAN ID of 2. This ensures that the untagged packets coming into the KS8995M on the WAN are tagged with a VLAN ID of 2 for internal switch use. All other packets received on port 4 should have a VLAN ID of 2.
 - a. Wr 44 02
7. Configure ingress VLAN filtering on port 4. This enables the KS8995M to discard packets with an invalid VLAN ID.
 - a. Wr 42 46

8. Enable tag insertion on port 5, the microprocessor port. This setting enables the KS8995M to insert the default VLAN ID of each untagged packet's ingress port before it is output from the KS8995M to the microprocessor. These tags, along with the source address, tell the microprocessor which port each packet was received from. *Note:* If tag insertion is enabled on any port and the port is in half-duplex mode, the port cannot be set for forced flow control. This is an illegal configuration, since half-duplex mode does not support flow control.
 - a. Wr 50 04
9. The microprocessor must tag all packets that it sends to port 5 on the KS8995M. The tag and destination address that the microprocessor inserts in each of its packets tells the switch whether to forward the packet to the WAN or the LAN, and to which port on the LAN. Note that packets coming from the LAN appear as if they are coming from a single source on the WAN.

Micrel's SPI Interface Commands

Uvtab [table entry #] vid=[vlan ID #] fid=[filtered ID #] mbr=[port membership] – update vlan table entry # with vlan id#, filtered id #, and port membership

Dvtab – dump vlan table entries

Wr [register # in hex] [value in hex] – write value to register

Rr [register # in hex] – read a register

Conclusion

Using the KS8995M and a microprocessor, the designer can create a cost effective gateway solution for the small office or home office. The KS8995M tag-based VLAN feature conquers three major issues in gateway implementations: Separating the LAN and WAN; preserving security integrity; and allowing MAC cloning. In addition, the KS8995M can be used for both the LAN and WAN interface reducing BOM costs.

References

Micrel's SPI configuration software.

For additional support, contact your local Micrel Field Application Engineer or salesperson.

MICREL, INC. 1849 FORTUNE DRIVE SAN JOSE, CA 95131 USA

TEL + 1 (408) 944-0800 FAX + 1 (408) 474-1000 WEB <http://www.micrel.com>

The information furnished by Micrel in this data sheet is believed to be accurate and reliable. However, no responsibility is assumed by Micrel for its use. Micrel reserves the right to change circuitry and specifications at any time without notification to the customer.

Micrel Products are not designed or authorized for use as components in life support appliances, devices or systems where malfunction of a product can reasonably be expected to result in personal injury. Life support devices or systems are devices or systems that (a) are intended for surgical implant into the body or (b) support or sustain life, and whose failure to perform can be reasonably expected to result in a significant injury to the user. A Purchaser's use or sale of Micrel Products for use in life support appliances, devices or systems is at Purchaser's own risk and Purchaser agrees to fully indemnify Micrel for any damages resulting from such use or sale.

© 2004 Micrel, Incorporated