

Integrated 5-Port 10/100 Managed Switch

The KS8995M is a highly integrated layer-2 managed switch with optimized BOM (Bill-Of-Materials) cost for low port count, cost-sensitive 10/100Mbps switch systems. It also provides an extensive feature set such as tag/port-based VLAN, QoS priority, management, MIB counters, dual MII interface and CPU control/data interfaces to effectively address both current and emerging Fast Ethernet applications.

The KS8995M contains five 10/100 transceivers with patented mixed-signal low-power technology, five MAC (Media Access Control) units, a high-speed non-blocking switch fabric, a dedicated address lookup engine, and an on-chip frame buffer memory.

All PHY units support 10Base-T and 100BaseTX. In addition, two of the PHY units support 100BaseFX (Ports 4 & 5).

Features

- Integrated switch with 5 MACs and 5 Fast Ethernet transceivers fully compliant to IEEE 802.3u standard
- Shared memory based switch fabric with fully non-blocking configuration
- 1.4Gbps high performance memory bandwidth
- 10BaseT, 100BaseTX and 100BaseFX modes (FX in Ports 4 & 5)
- Dual MII configuration: MII-Switch (MAC or PHY mode MII) and MII-P5 (PHY mode MII)
- IEEE 802.1q tag-based VLAN (16 VLANs, full-range VID) for DMZ port, WAN/LAN separation or inter-VLAN switch links
- VLAN ID tag/untag options, per-port basis
- Programmable rate limiting 0Mbps to 100Mbps, ingress and egress port, rate options for high and low priority, per port basis
- Flow control or drop packet rate limiting (ingress port)
- Integrated MIB counters for fully compliant statistics gathering, 34 MIB counters per port

Block Diagram

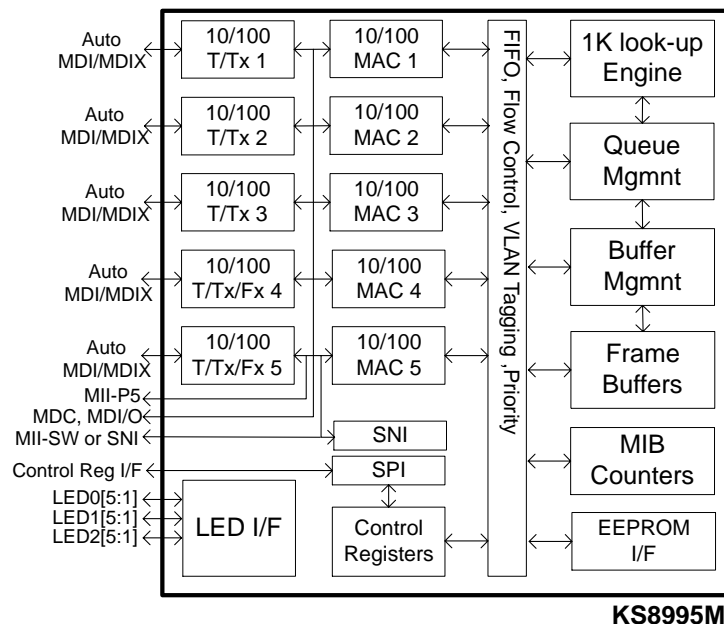

Features

- Enable/Disable option for huge frame size up to 1916 bytes per frame
- IGMP v1/v2 snooping for multicast packet filtering
- Special tagging mode to send CPU info on ingress packet's port value
- SPI slave (complete) and MDIO (MII PHY only) serial management interface for control of register configuration
- MAC-id based security lock option
- Control registers configurable on-the-fly (port-priority, 802.1p/d/q, AN...)
- CPU read access to MAC forwarding table entries
- 802.1d spanning tree protocol
- Port mirroring / monitoring / sniffing: ingress and/or egress traffic to any port or MII
- Broadcast storm protection with % control—global and per-port basis
- Optimization for fiber-to-copper media conversion
- Full-chip hardware power-down support (register configuration not saved)
- Per-port based software power-save on PHY (idle link detection, register configuration preserved)
- QoS / CoS packets prioritization supports: per port, 802.1p and DiffServ based
- 802.1p/q tag insertion or removal on a per port basis (egress)
- MDC and MDI/O interface support to access the MII PHY control registers (not all control registers)
- MII local loopback support
- On-chip 64kB memory for frame buffering (not shared with 1K unicast address table)
- Wire speed reception and transmission
- Integrated look-up engine with dedicated 1K MAC addresses
- Full duplex IEEE 802.3x and half-duplex back pressure flow control
- Comprehensive LED support
- 7-wire SNI support for legacy MAC interface
- Automatic MDI/MDI-X crossover for plug-and-play
- Low power, 1.8/2.5/3.3V, 0.18um CMOS technology
- Available in 128-pin PQFP package

Applications

- Broadband gateway/firewall/VPN
- Integrated DSL or cable modem multi-port router
- Wireless LAN access point + gateway
- Home networking expansion
- Standalone 10/100 switch
- Hotel/campus/MxU gateway
- Enterprise VoIP gateway/phone
- FTTx customer premise equipment
- Managed media converter

System Level Applications

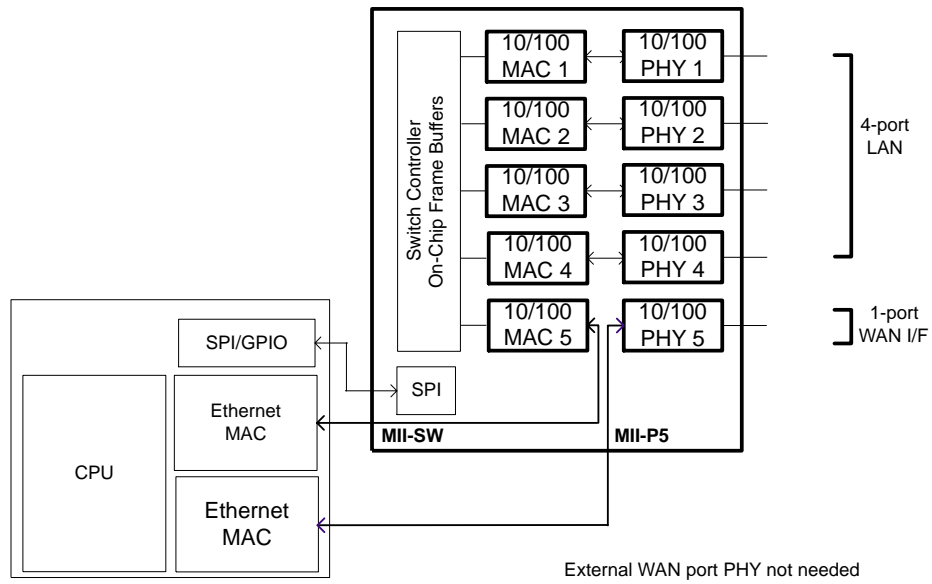

Figure 1. Broadband Gateway

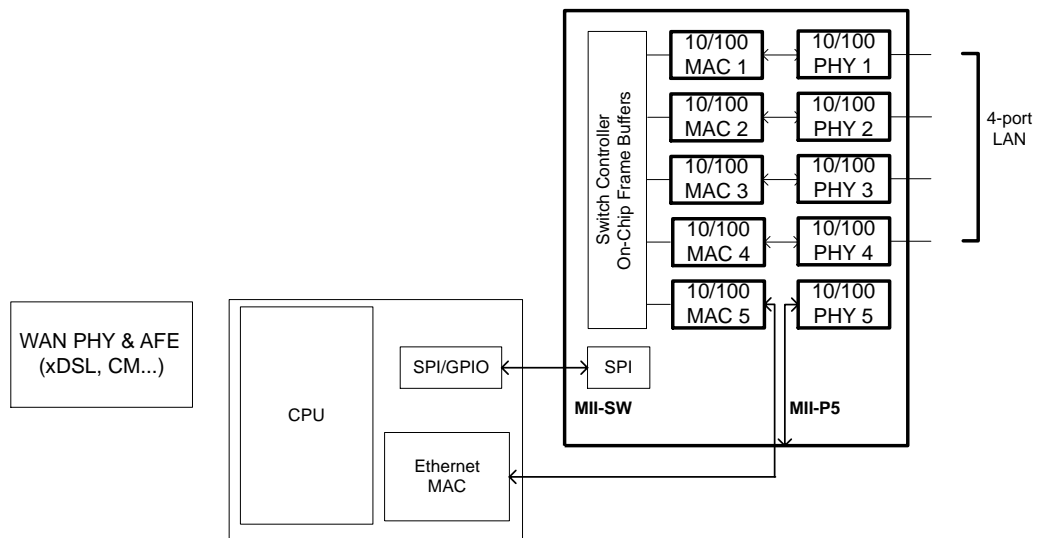

Figure 2. Integrated Broadband Router

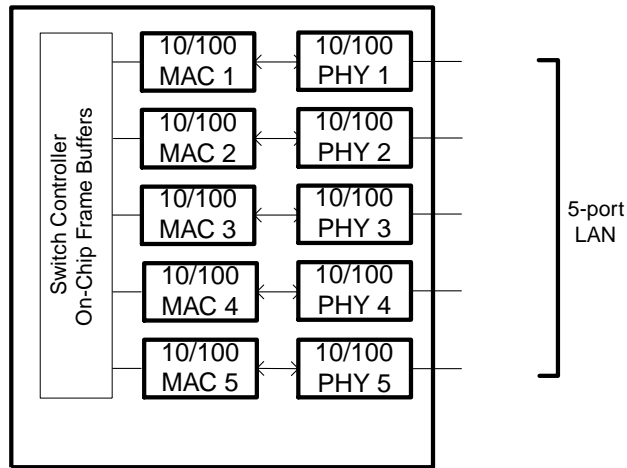

Figure 3. Standalone Switch

Contact Micrel Semiconductor

Location	Address		Telephone	Fax
Corporate HQ	1849 Fortune Drive	San Jose, CA 95131 USA	+1 (408) 944-0800	+1-408-944-0970
Eastern USA	93 Branch Street	Medford, NJ 08055 USA	+1 (609) 654-0078	+1 (609) 546-0989
Southeast USA	8105 Bluffridge Drive	Raleigh, NC 27615 USA	+1 (919) 870-7650	+1 (919) 870-7651
Central USA	722 S. Denton Tap Suite 130	Coppell, TX 75019 USA	+1 (972) 393-2533	+1 (972) 393-2540
Western USA	2180 Fortune Drive	San Jose, CA 95131 USA	+1 (408) 944-0800	+1-408-944-0970
Northwest USA	401 NE Ravenna Blvd. Box 152	Seattle, WA 98115 USA	+1 (206) 526-7299	+1 (206) 526-8829
Southwest USA	7545 Irvine Center Dr. Suite 200	Irvine, CA 92618 USA	+1 (949) 623-8343	+1 (949) 623-8305
Korea	4F, KTB Building, 826-14, Yeoksam-dong, Kangnam-ku	Seoul 135-080 Korea	+82 (2) 3466-3000	+82 (2) 3466-2999
Taiwan	7F-6, No. 237, Sec. 2, Fu-Hsing South Road	Taipei, Taiwan, R.O.C.	+886 (2) 2705-4976	+886 (2) 2705-4977
China	12A, XingHao City Garden	Shenzhen, P.R. China	+86 (755) 2693-4601	
Japan	1-16-15 Dogenzaka, Shibuyaku	Tokyo 150-0043 Japan	+81 (3) 5428-0871	+81 (3) 5428-0872
Europe	1st Floor, 3 Lockside Place, Mill Lane	Newbury, Berks RG14 5QS UK	+44 1635 524455	+44 1635 524466
Western Europe	10, avenue du Quebec, Villebon BP116	Courtaboeuf Cedex 91944 France	+33 (0) 1 6092 4189	+33 (0) 6 0868 4489

