



SY54023R/AR Evaluation Board

Low Voltage 1.2V/1.8V CML Differential
2x2 Crosspoint (with FAIL SAFE INPUTS)

General Description

The SY54023R and SY54023AR evaluation boards are designed for convenient set-up and quick evaluation of the respective devices. They allow the user to evaluate the part over the full voltage-range of the parts without requiring any modifications to the board.

The evaluation board standard configuration is AC-coupled inputs with DC-coupled outputs for direct interface to a 50Ω-compatible oscilloscope. For applications that require a DC-coupled configuration, step-by-step instructions for modifying the board are included.

All datasheets and support documentation can be found at Micrel's web site at: www.micrel.com.

Features

- SY54023R/AR 1.2V/1.8V CML outputs
- Single +2.5V VCC with 1.2V/1.8V VCCO supply
- AC-coupled configuration for ease-of-use
- I/O interface includes on-board termination
- Fully assembled and tested
- Reconfigurable for DC-coupled operation

Applications

- SY54023R Low Voltage 1.2V/1.8V CML Differential 2x2 Crosspoint with Fail Safe Inputs Datasheet
- SY54023AR Low Voltage 1.2V/1.8V CML Differential 2x2 Crosspoint Datasheet

Evaluation Board

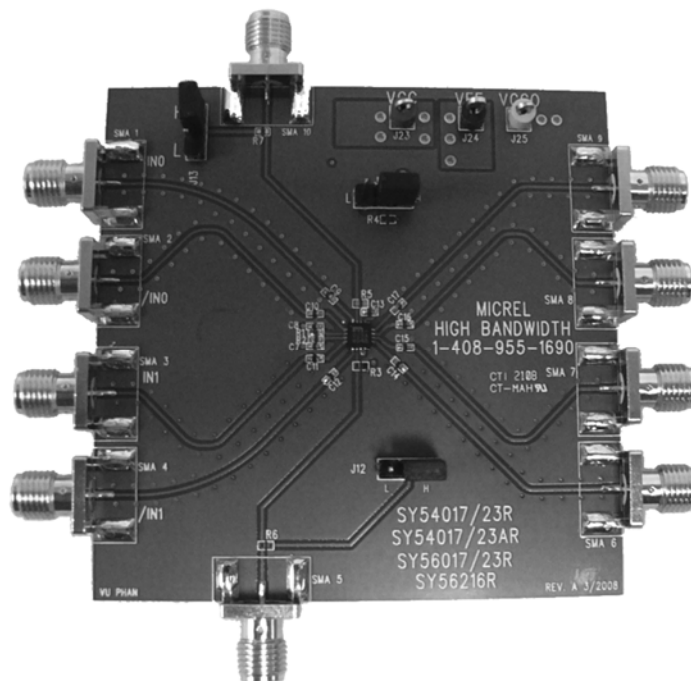

Evaluation Board Description

The SY54023R and SY54023AR share a common evaluation board. The boards are designed to accept either AC-coupled or DC-coupled inputs, however, all boards are shipped with DC-coupled outputs. The DC-coupled outputs allow the CML output to be connected directly to a scope with the standard termination of 50Ω-to-ground. This is accomplished by tying the body of the SMA connectors to the V_{CC0} supply on the evaluation board so that the scope termination appears as 50Ω-to- V_{CC0} on the board. This allows the body of the SMA connectors, which are scope GND, to appear at the same potential as V_{CC0} for the CML output drivers.

The default configuration for the boards is AC-coupled inputs and DC-coupled outputs and all boards are shipped with this configuration. The choice between two configurations, AC-coupled or DC-coupled, offers the user flexibility in selecting the board that is right for his particular application.

Step-by-step instructions for modifying an AC-coupled evaluation board for DC-coupled operation are supplied in the section “Modifying your AC-Coupled Board for DC-Coupled Operation.”

If the output is connected to an AC-coupled 50Ω termination, the 1.2V operation may not work due to a 200mV output level shift from the output coupling capacitors.

SY54023R/AR AC-Coupled Evaluation Board (AC-Coupled Input, DC-Coupled Output)

For a 1.2V output configuration, the V_{CC} of the board is set to 2.5V and the V_{CC0} is set to 1.2V. For a 1.8V output configuration, the V_{CC0} is set to 1.8V. For both the 1.2V and 1.8V configuration the V_{EE} is set to 0V.

Setting up the AC-Coupled Evaluation Board (AC-Coupled Input, DC-Coupled Output)

The following steps describe the procedure for setting up the CML-output evaluation board:

Setting up the Power Supplies:

1. Set the voltage setting for a DC supply to 2.5V and turn off the supply.
2. Set the voltage setting for a second DC supply to be either 1.2V or 1.8V and turn off the supply.
3. Connect the negative terminal of the two power supplies together and connect to the V_{EE} terminal of the evaluation board.
4. Do not earth ground either supply.

5. Turn on the power supplies and verify that the 2.5V supply current is <60mA and 1.2V/1.8V supply is <50mA.
6. Turn off the power supplies.

Setting up the AC-Coupled Input

1. Using a differential signal source set the HIGH level of each side of the differential pair to be 0.4V and the LOW level to be 0V. Note that for AC-coupled inputs, only the signal swing is significant, since the inputs will be re-biased after the series capacitor. The amplitude of the input swing can be any value between 100mV and 1.0V.
2. Using equal length 50Ω impedance coaxial cables, connect the signal source to the desired input(s) (Pin 1 and Pin 16 for IN0; Pin 4 and Pin5 for IN1).

SEL0/J13	SEL1/J12	Q0	Q1
L	L	IN0	IN0
L	H	IN0	IN1
H	L	IN1	IN0
H	H	IN1	IN1

Table 1. Truth Table

Setting up the DC-Coupled Output

1. Select the input to output combination desired by using jumpers J12 and J13. Please refer to Table 1 above.
2. Using equal length 50Ω impedance coaxial cables connect the SMA outputs of the evaluation board (Pin 11 and Pin 12 for Q0; Pin 9 and Pin 10 for Q1) to the oscilloscope or other measurement device that has an internal DC-coupled 50Ω termination. If only one output is connected to the oscilloscope, the complementary output must still be terminated with a 50Ω termination. The second output pair also needs to be terminated into 50Ω.
3. Turn on the power supplies and verify that the 2.5V supply current is <60mA and 1.2V/1.8V supply is <50mA.
4. Enable the signal source and monitor the outputs.
5. If an external clock signal is used to drive the SEL0 and SEL 1 pins for testing purposes, please add a 50Ω resistor to R3 and R5 in order to terminate the trace. In addition, remove R6 and R7.

Evaluation Board

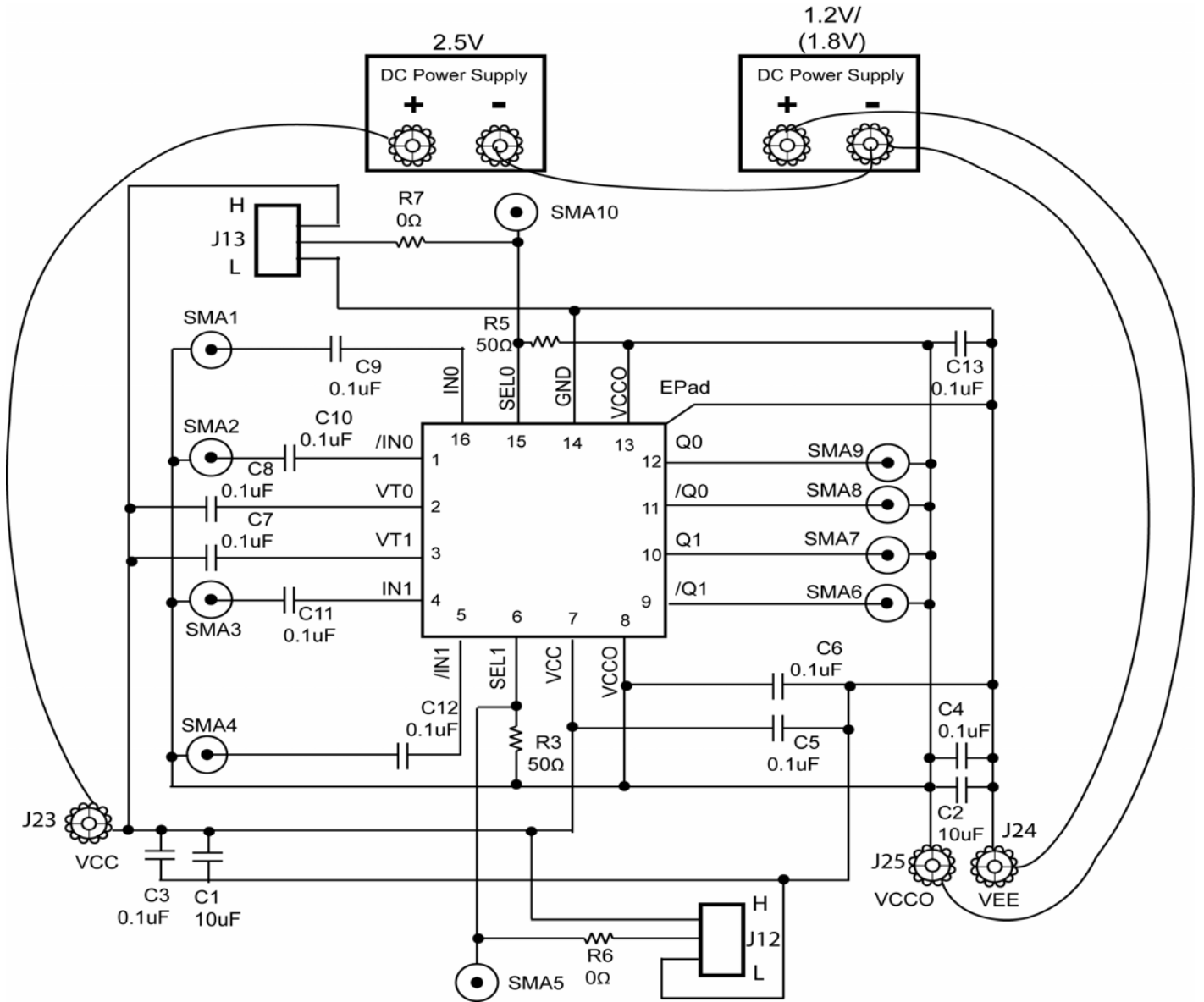

SY54023R and SY54023AR AC-Coupled Evaluation Board

Power Supply	V _{CC}	V _{CCO}	V _{EE}	I/O
1.2V Output	2.5V	1.2V	0V	AC-Coupled Input/DC-Coupled Output
1.8V Output	2.5V	1.8V	0V	AC-Coupled Input/DC-Coupled Output

Table 2. SY54023R/AR AC-Coupled Evaluation Board Power Supply Connections

Bill of Materials

SY54023R/AR Evaluation Board

Item	Part Number	Manufacturer	Description	Qty.
C5-C13	VJ0402Y104KXXAT	Vishay ⁽¹⁾	0.1 μ F, 25V, 10% Ceramic Capacitor, Size 0402, X7R Dielectric	9
C1,C2	293D106X0010	Vishay ⁽¹⁾	10 μ F, 20V, Tantalum Electrolytic Capacitor, Size C	2
C3, C4	VJ0805Y104KXXAT	Vishay ⁽¹⁾	0.1 μ F, 25V, 10% Ceramic Capacitor, Size 0805	2
R6, R7	CRCW040200R0F	Vishay ⁽¹⁾	0 Ω , 1/16W, 5% Thick-film Resistor, Size 0402, X7R Dielectric	1
R3, R5	CRCW040249R9F	Vishay ⁽¹⁾	50 Ω 1/16W, 5% Thick-film Resistor, Size 0402, X7R Dielectric	1
J23			Red Test Point (V _{CC})	1
J24			Black Test Point (GND)	1
J25			Yellow Test Point (V _{EE})	1
J12, J13	PZC365FBN	Vishay ⁽¹⁾	3-pin Jumper	1
SMA1-SMA10	142-0701-851	Johnson Components ⁽²⁾	Jack Assembly End Launch SMA	7
U1	SY54023R/AR	Micrel⁽³⁾	Low Voltage 1.2V/1.8V CML Differential Line Driver/Receiver	1

Notes:

1. Vishay: www.vishay.com.
2. Johnson Components: www.johnsoncomponents.com.
3. Micrel, Inc.: www.micrel.co

Additional Bill of Materials for SY54023R/AR DC-Coupled Evaluation Board

Item	Part Number	Manufacturer	Description	Qty.
C9-C12	CRCW040200R0F	Vishay ⁽¹⁾	Replace with 0 Ω , 1/16W, 5% Thick-film Resistor, Size 0402, X7R Dielectric	4
R1,R2	CRCW040200R0F	Vishay ⁽¹⁾	Add 0 Ω , 1/16W, 5% Thick-film Resistor, Size 0402, X7R Dielectric	2

Notes:

1. Vishay: www.vishay.com

PC Board Layout

Board Layout

The evaluation boards are constructed with Rogers 4003 material, are co-planer in design, fabricated to minimize noise, achieve high bandwidth and minimize crosstalk.

L1	Signal
L2	V _{CCO} Power
L3	V _{CC} Power
L4	V _{EE} Power
L5	V _{CCO} Power
L6	Signal

Table 3. Layer Stack

Modifying the AC-Coupled Board for DC-Coupled Operation

When DC-Coupling is Necessary

For applications where AC-Coupling of the inputs is not appropriate, the board can be reconfigured for DC-Coupled input operation.

Reconfiguring AC-Coupled Inputs to be DC-Coupled Inputs

The following procedure details the steps for converting an AC-coupled board to a DC-coupled board.

1. Replace capacitors C9-C12 with 0Ω resistors.
2. Add R1 and R2, 0Ω resistors.

Setting up the SY54023R/AR DC-Coupled Evaluation Board (DC-Coupled Input, DC-Coupled Output)

The following steps describe the procedure for setting up the CML-output evaluation board:

Setting up the Power Supplies

1. Set the voltage setting for a DC supply to be 2.5V and turn off the supply.
2. Set the voltage setting for a second DC supply to be either 1.2V or 1.8V and turn off the supply.
3. Connect the negative terminal of the two power supplies together and connect to the V_{EE} terminal of the evaluation board.
4. Do not earth ground either supply.
5. Turn on the power supplies and verify that the 2.5V supply current is <60mA and 1.2V/1.8V supply is <50mA.
6. Turn off the power supply.

Setting up the DC-Coupled Input

1. Using a differential signal source set the HIGH level of each side of the differential pair to be 0.4V and the LOW level to be 0V. Turn off or disable the outputs of the signal source. Note that when the inputs are DC-coupled they are referenced to V_{CCO} because the body of the SMA connectors is tied to V_{CCO}. That means an input level of 0.4V from the signal source will appear as 0.4V + V_{CCO} to the device. For example, if the HIGH level is 0.4V and the V_{CCO} is 1.8V, the device will see 2.2V at its inputs. Since the maximum input HIGH is V_{CC}, if V_{CC} = 2.5V and V_{CCO} = 1.8V, the maximum HIGH level is 0.7V. Please refer to Table 4 below.

Source Level	V _{CCO}	Input	Max Input for V _{CC} =2.5V
0.7	1.8	2.5	Input ≤ V _{CC}
1.3	1.2	2.5	Input ≤ V _{CC}

Table 4. Source Levels as a Function of V_{CCO}

2. Using equal length 50Ω impedance coaxial cables, connect the signal source to the desired input(s) (Pin 1 and Pin 16 for IN0; Pin 4 and Pin5 for IN1).

Setting up the DC-Coupled Output

1. Select the input to output combination desired by using jumpers J12 and J13. Please refer to Table 1.
2. Using equal length 50Ω impedance coaxial cables connect the SMA outputs of the evaluation board (Pin 11 and Pin 12 for Q0; Pin 9 and Pin 10 for Q1) to the oscilloscope or other measurement device that has an internal DC-Coupled 50Ω termination. If only one output is connected to the oscilloscope, the complementary output must still be terminated with 50Ω termination. The second output pair also needs to be terminated into 50Ω.
3. Turn on the power supplies and verify that the 2.5V supply current is <60mA and 1.2V/1.8V supply is <50mA.
4. Enable the signal source and monitor the outputs.
5. If an external clock signal is used to drive the SEL0 and SEL 1 pins for testing purposes, please add a 50Ω resistor to R3 and R5 in order to terminate the trace. In addition, remove R6 and R7.

Evaluation Board

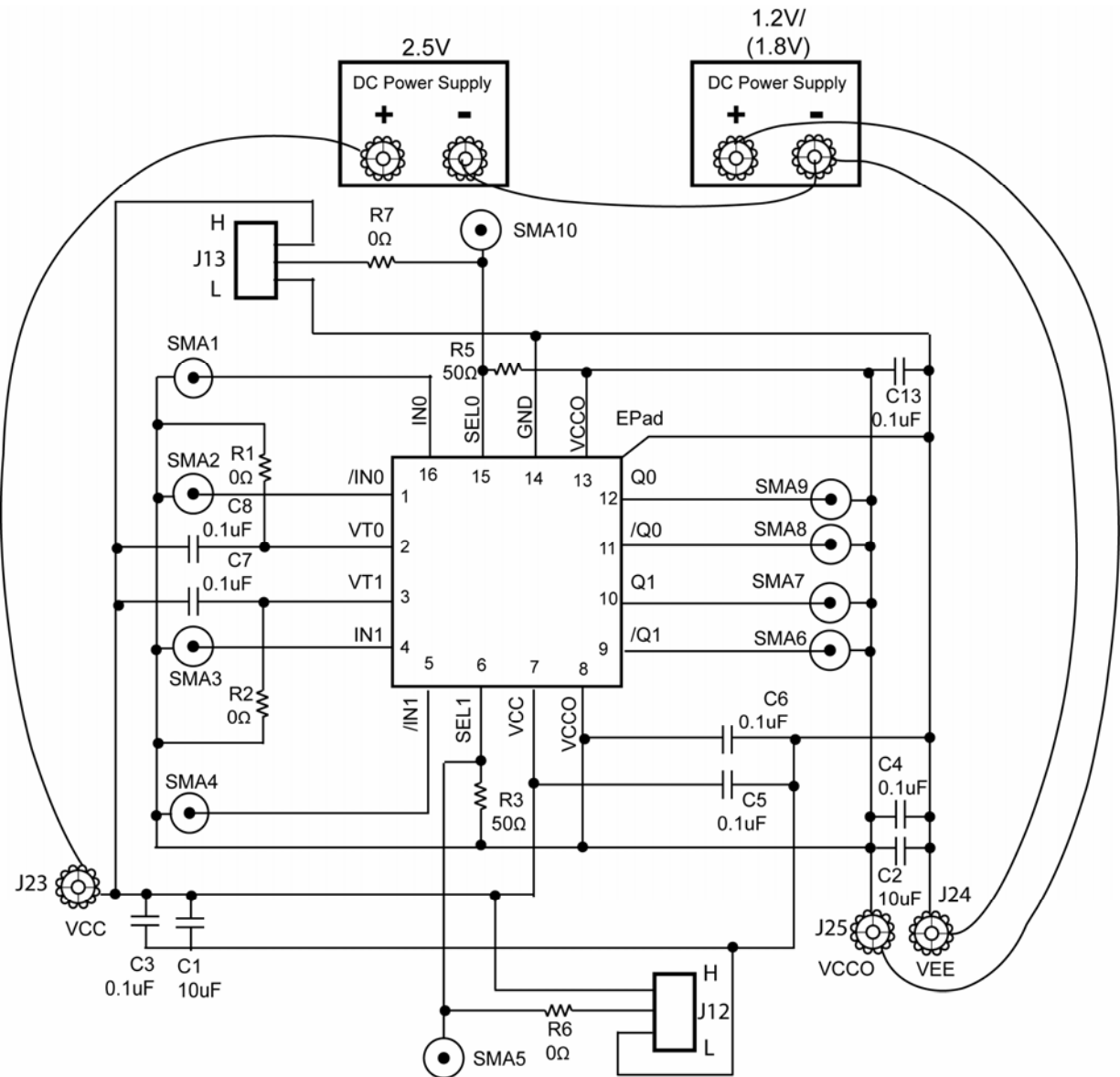

SY54023R and SY54023AR DC-Coupled Evaluation Board

Power Supply	V _{cc}	V _{cco}	V _{EE}	I/O
1.2V Output	2.5V	1.2V	0V	DC-Coupled Input/DC-Coupled Output
1.8V Output	2.5V	1.8V	0V	DC-Coupled Input/DC-Coupled Output

Table 5. SY54023R/AR DC-Coupled Evaluation Board Power Supply Connections

HBW Support

Hotline: 408-955-1690

Email Support: HBWHelp@micrel.com

Application Hints and Notes

For application notes on high speed termination on PECL and LVPECL products, clock synthesizer products, SONET jitter measurement, and other High Bandwidth product go to Micrel Inc., website at <http://www.micrel.com/>. Once in Micrel's website, follow the steps below:

1. Click on "Product Info".
2. In the Applications Information Box, choose "Application Hints and Application Notes."

MICREL, INC. 2180 FORTUNE DRIVE SAN JOSE, CA 95131 USA
TEL +1 (408) 944-0800 FAX +1 (408) 474-1000 WEB <http://www.micrel.com>

The information furnished by Micrel in this data sheet is believed to be accurate and reliable. However, no responsibility is assumed by Micrel for its use. Micrel reserves the right to change circuitry and specifications at any time without notification to the customer.

Micrel Products are not designed or authorized for use as components in life support appliances, devices or systems where malfunction of a product can reasonably be expected to result in personal injury. Life support devices or systems are devices or systems that (a) are intended for surgical implant into the body or (b) support or sustain life, and whose failure to perform can be reasonably expected to result in a significant injury to the user. A Purchaser's use or sale of Micrel Products for use in life support appliances, devices or systems is a Purchaser's own risk and Purchaser agrees to fully indemnify Micrel for any damages resulting from such use or sale.

© 2008 Micrel, Incorporated.