



SY56016R Evaluation Board

Low Voltage 1.2V/1.8V/2.5V CML
Differential Line Driver/Receiver 6.4Gbps
with Equalization

General Description

The SY56016R evaluation board is designed for convenient set-up and quick evaluation. It allows the user to evaluate the part over the full voltage-range of the part without requiring any modification to the board.

The evaluation board standard configuration is AC-coupled inputs with DC-coupled outputs for direct interface to a 50Ω-compatible oscilloscope. For applications that require a DC-coupled configuration, step-by-step instructions for modifying the board are included.

All datasheets and support documentation can be found at Micrel's web site at: www.micrel.com.

Features

- SY56016R 1.2V/1.8V/2.5V CML outputs
- Single 2.5V VCC with 1.2V/1.8V/2.5V VCCO supply
- AC-coupled configuration for ease-of-use
- I/O interface includes on-board termination
- Fully assembled and tested
- Reconfigurable for DC-coupled operation

Applications

- SY56016R Low Voltage 1.2V to 2.5V CML Differential Line Driver/Receiver 6.4Gbps with Equalization

Evaluation Board

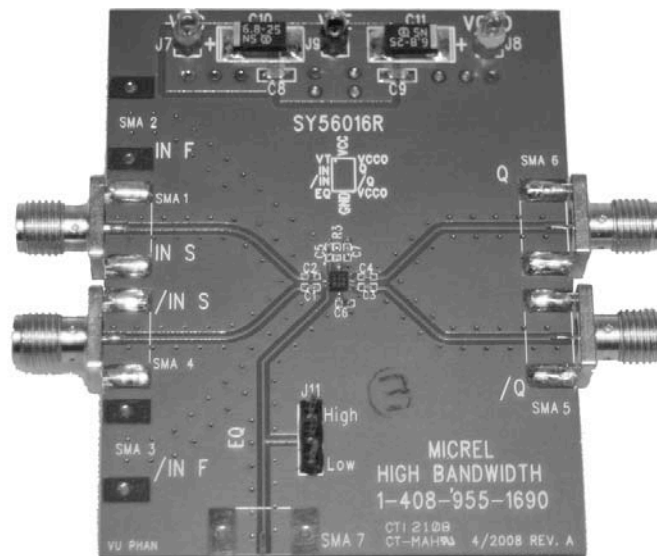

Evaluation Board Description

The SY56016R evaluation board is designed to accept either AC-coupled or DC-coupled inputs; however, all boards are shipped with DC-Coupled outputs. The DC-coupled outputs allow the CML output to be connected directly to a scope with the standard termination of 50Ω-to-ground. This is accomplished by tying the body of the SMA connectors to the V_{CC0} supply on the evaluation board so that the scope termination appears as 50Ω-to- V_{CC0} on the board. This allows the body of the SMA connectors, which are scope GND, to appear at the same potential as V_{CC0} for the CML output drivers.

The choice between the two configurations, AC-Coupled or DC-Coupled inputs, offers the user flexibility in selecting the board that is right for the given application.

Step-by-step instructions for modifying an AC-coupled evaluation board for DC-coupled operation are supplied in the section "Modifying your AC-Coupled Board for DC-Coupled Operation."

If the output is connected to an AC-coupled 50Ω termination, the 1.2V operation may not work due to a 200mV output level shift from the output coupling capacitors.

SY56016R AC-Coupled Evaluation Board (AC-Coupled Input, DC-Coupled Output)

For a 1.2V output configuration, the V_{CC} of the board is set to 2.5V and the V_{CC0} is set to 1.2V. For a 1.8V output configuration the V_{CC0} is set to 1.8V. For a full 2.5V operation, short V_{CC0} to V_{CC} . For all configurations the V_{EE} is set to 0V.

Setting up the AC-Coupled Evaluation Board (AC-Coupled Input, DC-Coupled Output)

The following steps describe the procedure for setting up the CML-output evaluation board:

Setting up the Power Supplies:

1. Set the voltage setting of a DC supply to 2.5V and turn off the supply.
2. Set the voltage setting for a second DC supply to be 1.2V, 1.8V or 2.5V and turn off the supply.
3. 2.5V output operation can also be achieved by shorting V_{CC0} to V_{CC} and operating with one supply.
4. Connect the negative terminal of the two power supplies together and connect to the V_{EE} terminal of the evaluation board.

5. Do not earth ground either supply.
6. Turn on the power supplies and verify that the 2.5V supply current is <50mA and 1.2V/1.8V/2.5V supply is <25mA. If using one supply, <75mA.
7. Turn off the power supplies.

Setting up the AC-Coupled Input

1. Using a differential signal source set the HIGH level of each side of the differential signal pair to be 0.4V and the LOW level to be 0V. Note that for AC-coupled inputs, only the signal swing is significant, since the input will be re-biased after the series capacitor. The amplitude of the input swing can be any value between 200mV and 1.0V.
2. Using equal length 50Ω impedance coaxial cables, connect the signal source to the desired attenuation line and then connect to the input, IN and /IN, on the evaluation board. Make sure the length of each attenuation line is matched to each other.
3. The equalization can be selected through the EQ pin (Pin 4), which is connected to the J11 jumper. The EQ setting depends on the length of the attenuation line. Please refer to Table 1 below for the desired equalization selection.

EQ	FR4 Equalization
LOW(L)	9"
FLOAT	18"
HIGH(H)	27"

Table 1. EQ Setting

Setting up the DC-Coupled Output

1. Using equal length 50Ω impedance coaxial cables connect the SMA output pair of the evaluation board (Pin 8 and Pin 7) to the oscilloscope or other measurement device that has an internal DC-Coupled 50Ω termination. If only the true output is connected to the oscilloscope, the complementary output must still be terminated with a 50Ω termination.
2. Turn on the power supplies and verify that the 2.5V supply current is <50mA and 1.2V/1.8V/2.5V supply is <25mA. If using one supply, <75mA.
3. Enable the signal source and monitor the output

Evaluation Board

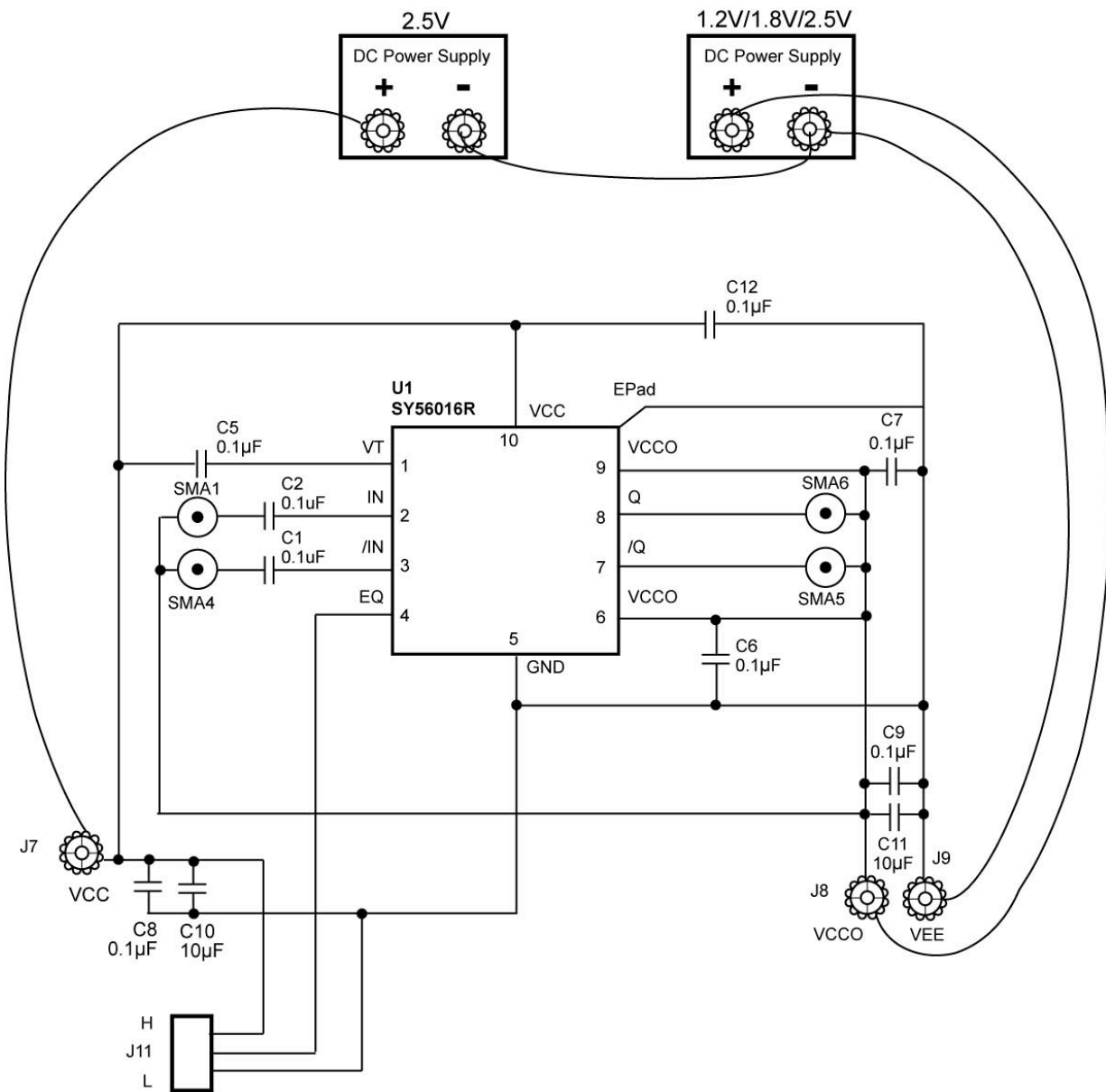

SY56016R AC-Coupled Evaluation Board

Power Supply	V _{CC}	V _{CCO}	V _{EE}	I/O
1.2V Output	2.5V	1.2V	0V	AC-Coupled Input/DC-Coupled Output
1.8V Output	2.5V	1.8V	0V	AC-Coupled Input/DC-Coupled Output
2.5V Output	2.5V	2.5V	0V	AC-Coupled Input/DC-Coupled Output

Table 2. SY56016R AC-Coupled Evaluation Board Power Supply Connections

PC Board Layout

Board Layout

The evaluation boards are constructed with Rogers 4003 material, are co-planer in design, fabricated to minimize noise, achieve high bandwidth and minimize crosstalk.

L1	Signal
L2	V _{CCO} Power
L3	V _{CC} Power
L4	V _{EE} Power
L5	V _{CCO} Power
L6	Signal

Table 3. Layer Stack

Modifying the AC-Coupled Board for DC-Coupled Operation

When DC-Coupling is Necessary

For applications where AC-coupling of the input is not appropriate, the board can be reconfigured for DC-coupled input operation.

Reconfiguring AC-Coupled Inputs to be DC-Coupled Inputs

The following procedure details the steps for converting an AC-coupled board to a DC-coupled board.

1. Replace capacitors C1 and C2 with 0Ω resistors.
2. Add R3 0Ω resistor.

Setting up the SY56016R DC-Coupled Evaluation Board (DC-Coupled Input, DC-Coupled Output)

The following steps describe the procedure for setting up the CML-output evaluation board:

Setting up the Power Supplies

1. Set the voltage setting for a DC supply to be 2.5V and turn off the supply.
2. Set the voltage setting for a second DC supply to be 1.2V, 1.8V or 2.5V and turn off the supply.
3. 2.5V output operation can also be achieved by shorting V_{CCO} to V_{CC} and operating with one supply.
4. Connect the negative terminal of the two power supplies together and connect to the V_{EE} terminal of the evaluation board.
5. Do not earth ground either supply.

6. Turn on the power supplies and verify that the 2.5V supply current is <50mA and 1.2V/1.8V/2.5V supply is <25mA. If using one supply, <75mA.
7. Turn off the power supply.

Setting up the DC-Coupled Input

1. When the input is DC-coupled, they are referenced to V_{CCO} because the body of the SMA connectors is tied to V_{CCO}. Therefore, the device HIGH and LOW input voltage levels will change depending on V_{CCO}. To make the input HIGH level 1.8V and LOW level 1.4V, follow Table 5 to program the differential signal source. If the levels are varied, make sure they remain within the datasheet input range.

V _{CCO}	HIGH	LOW
1.2	0.6V	0.2V
1.8	0V	-0.4V
2.5	-0.7V	-1.1V

Table 4. Source Levels as a Function of V_{CCO}

2. Using equal length 50Ω impedance coaxial cables, connect the signal source to the desired attenuation line and then connect to the input, IN and /IN, on the evaluation board. Make sure the length of each attenuation line is matched to each other.
3. The equalization can be selected through the EQ pin (Pin 4), which is connected to the J11 jumper. The EQ setting depends on the length of the attenuation line. Please refer to Table 1 for the desired equalization selection.

Setting up the DC-Coupled Output

1. Using equal length 50Ω impedance coaxial cables connect the SMA output pair of the evaluation board (Pin 8 and Pin 7 for Q) to the oscilloscope or other measurement device that has an internal DC-Coupled 50Ω termination. If only the true output is connected to the oscilloscope, the complementary output must still be terminated with a 50Ω termination.
2. Turn on the power supplies and verify that the 2.5V supply current is <50mA and 1.2V/1.8V/2.5V supply is <25mA. If using one supply, <75mA.
3. Enable the signal source and monitor the output.

Evaluation Board

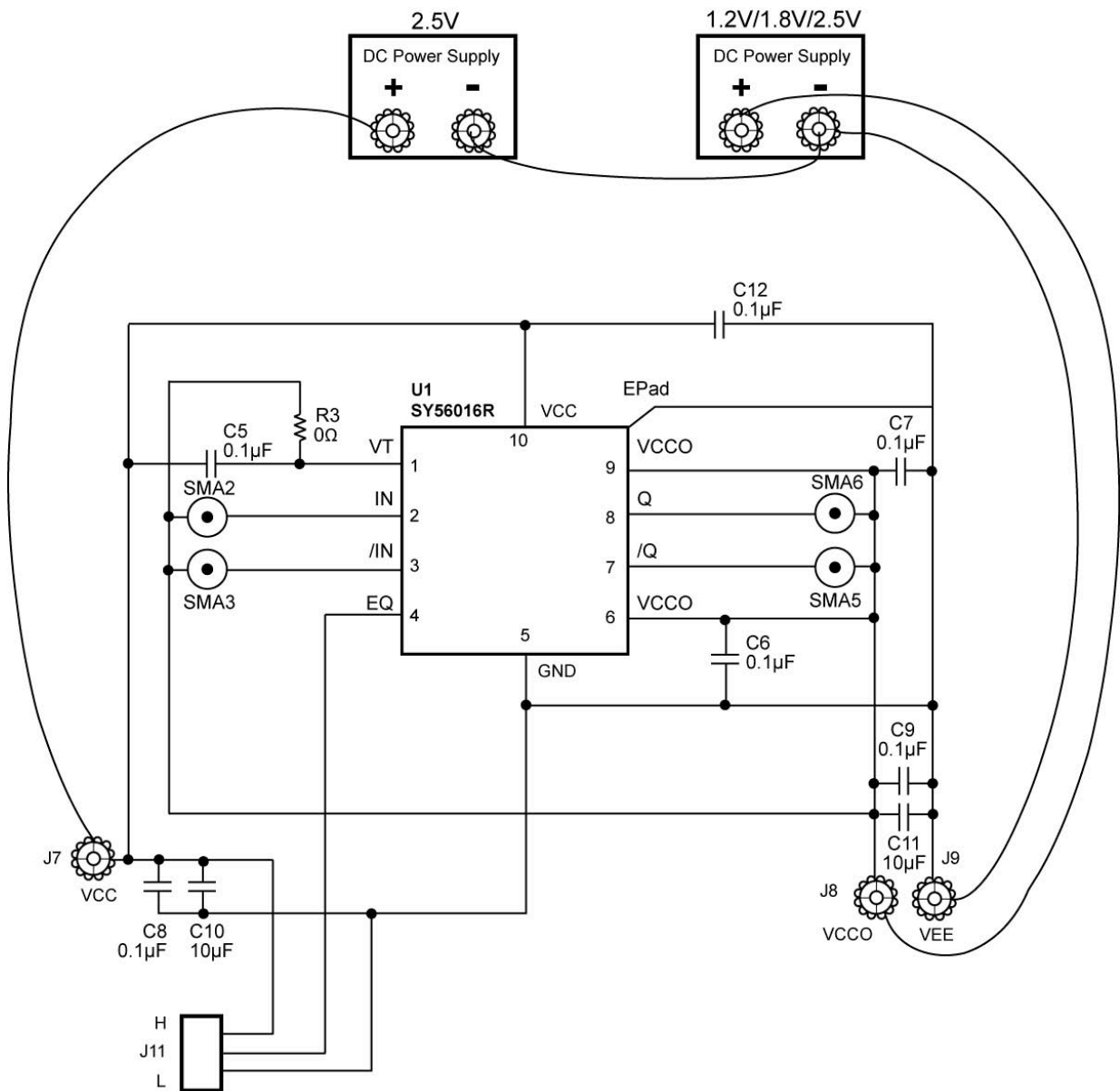

SY56016R DC-Coupled Evaluation Board

Power Supply	V _{CC}	V _{CCO}	V _{EE}	I/O
1.2V Output	2.5V	1.2V	0V	DC-Coupled Input/DC-Coupled Output
1.8V Output	2.5V	1.8V	0V	DC-Coupled Input/DC-Coupled Output
2.5V Output	2.5V	2.5V	0V	DC-Coupled Input/DC-Coupled Output

Table 5. SY56016R DC-Coupled Evaluation Board Power Supply Connection

Bill of Materials

SY56016R Evaluation Board

Item	Part Number	Manufacturer	Description	Qty.
C1-C7, C12	VJ0402Y104KXXAT	Vishay ⁽¹⁾	0.1 μ F, 25V, 10% Ceramic Capacitor, Size 0402, X7R Dielectric	8
C10, C11	293D106X0010	Vishay ⁽¹⁾	10 μ F, 20V, Tantalum Electrolytic Capacitor, Size C	2
C8, C9	VJ0805Y104KXXAT	Vishay ⁽¹⁾	0.1 μ F, 25V, 10% Ceramic Capacitor, Size 0805	2
J7			Red Test Point (V_{CC})	1
J9			Black Test Point (V_{EE})	1
J8			Yellow Test Point (V_{CCO})	1
J11	PZC365FBN	Vishay ⁽¹⁾	3-pin Jumper	1
SMA1-SMA4 SMA5, SMA6	142-0701-851	Johnson Components ⁽²⁾	Jack Assembly End Launch SMA	6
U1	SY56016R	Micrel, Inc. ⁽³⁾	Low Voltage 1.2V to 2.5V CML Differential Line Driver/Receiver 6.4Gbps with Equalization	1

Additional Bill of Materials for SY56016R DC-Coupled Evaluation Board

Item	Part Number	Manufacturer	Description	Qty.
R1, R2	CRCW040200R0F	Vishay ⁽¹⁾	0 Ω , 1/16W, 5% Thick-film Resistor, Size 0402	2
R3	CRCW040200R0F	Vishay ⁽¹⁾	Add 0 Ω , 1/16W, 5% Thick-film Resistor, Size 0402	1
SMA2, SMA3	142-0701-851	Johnson Components ⁽²⁾	Jack Assembly End Launch SMA	6

Notes:

1. Vishay: www.vishay.com.
1. Johnson Components: www.johnsoncomponents.com.
3. **Micrel, Inc.:** www.micrel.com.

HBW Support

Hotline: 408-955-1690

Email Support: HBWHelp@micrel.com

Application Hints and Notes

For application notes on high speed termination on PECL and LVPECL products, clock synthesizer products, SONET jitter measurement, and other High Bandwidth product go to Micrel Inc., website at <http://www.micrel.com/>. Once in Micrel's website, follow the steps below:

1. Click on "Product Info".
2. In the Applications Information Box, choose "Application Hints and Application Notes."

MICREL, INC. 2180 FORTUNE DRIVE SAN JOSE, CA 95131 USA

TEL +1 (408) 944-0800 FAX +1 (408) 474-1000 WEB <http://www.micrel.com>

The information furnished by Micrel in this data sheet is believed to be accurate and reliable. However, no responsibility is assumed by Micrel for its use. Micrel reserves the right to change circuitry and specifications at any time without notification to the customer.

Micrel Products are not designed or authorized for use as components in life support appliances, devices or systems where malfunction of a product can reasonably be expected to result in personal injury. Life support devices or systems are devices or systems that (a) are intended for surgical implant into the body or (b) support or sustain life, and whose failure to perform can be reasonably expected to result in a significant injury to the user. A Purchaser's use or sale of Micrel Products for use in life support appliances, devices or systems is a Purchaser's own risk and Purchaser agrees to fully indemnify Micrel for any damages resulting from such use or sale.

© 2008 Micrel, Incorporated.