



DC-to-6.4Gbps Backplane Transmit Buffer with Selectable Output Pre-emphasis, I/O DC-Offset Control, and 200mV-3.0mV_{PP} Output Swing

SY58626L Evaluation Board

General Description

The SY58626L evaluation board is designed for convenient setup and quick evaluation of the SY58626L backplane transmit buffer. The board is optimized to interface directly to a 50Ω oscilloscope.

For best evaluation of the features of this part, the board is configured in DC-coupled In and DC-coupled Out configuration. For applications that require an AC-coupled configuration, step-by-step instructions for modifying the board are included.

All data sheets and support documentation can be found on Micrel's web site at: www.micrel.com.

Features

- +3.3V power supply for the SY58626L
- DC-coupled configuration
- I/O interface includes on-board termination
- Fully assembled and tested
- Can be reconfigured for AC-coupled operation

Related Documentation

- SY58626L DC-to-6.4Gbps Backplane Transmit Buffer with Selectable Output Pre-emphasis, I/O DC-Offset Control, and 200mV-3.0mV_{PP} Output Swing

Evaluation Board

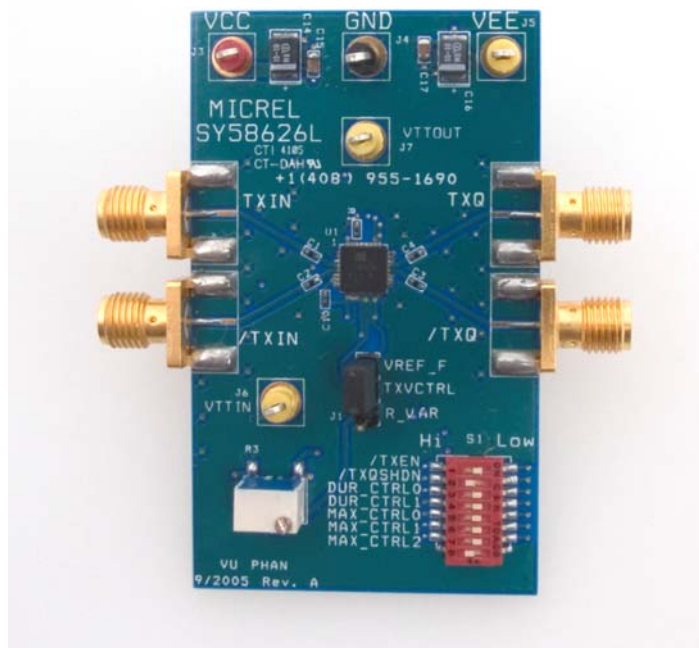

Evaluation Board Description

The default configuration for the SY58626L board is DC-coupled. The choice between AC- and DC-coupled configurations offers the user flexibility for specific applications.

DC-Coupled Evaluation Board

The SY58626L default configuration is set up for DC-coupled operation. In the DC-coupled configuration, the input and output voltage offset can be easily adjusted to interface directly with a variety of logic levels. Adjustable VCC, VEE, VTTIN, VTTOUT, and output swing provides maximum I/O versatility.

Determining the output voltage offset, while interfacing the SY58626L evaluation board to a 50 Ω -to-GND scope, can be accomplished using the following calculations:

1. The V_{OH} output is set by the voltage divider between the 50 Ω to VTTOUT resistor (internal) and the 50 Ω -to-GND resistor (scope). Therefore, the V_{OH} level of the output is the center voltage between VTTOUT and GND.
2. The V_{OL} output level is dependent on the output voltage swing selected. For example, if the jumper is between VREF-F and TXVCTRL, where the output swing is 400mV, the V_{OL} level will be 400mV below the V_{OH} output level.

For quick evaluation of the SY58626L, connect V_{CC}, VTTIN, VTTOUT, and GND to 0V and V_{EE} to -3.3V. This sets VTTOUT and the scope ground to the same potential, setting the V_{OH} level at approximately 0V.

AC-Coupled Evaluation Board

The SY58626L evaluation board can be reconfigured for AC-coupled operation. It requires only a single power supply and easily interfaces with a 50 Ω -to-GND scope.

After the SY58626L board is reconfigured for AC-coupled operation, the unique internal input termination sets the input common mode voltage. This enables the input to interface with any differential signal over the supply voltage without modifying the board.

Transmitter Variable-Swing Output

The SY58626L evaluation board allows the user to evaluate the variable output swing controls. The variable output swing buffer provides programmable output swing control from 100mV to 1.5V_{PK}.

By placing a jumper across TXVCTRL and R_VAR, the user can vary the resistance across the POT, changing the output swing in the process. When a jumper is placed between VREF-F and TXVCTRL, the output buffer is set to a fixed 400mV swing.

Output Disable and Shutdown

The SY58626L provides two methods to turn off the output buffer. When /TXEN is pulled HIGH, the output buffer is disabled. TXQ output switches to a LOW state and /TXQ output switches to a HIGH state. When TXQSHDN is pulled low, the output buffer is in shutdown mode. TXQ and /TXQ output currents are shut off and the outputs are set to the same potential.

Evaluation Board

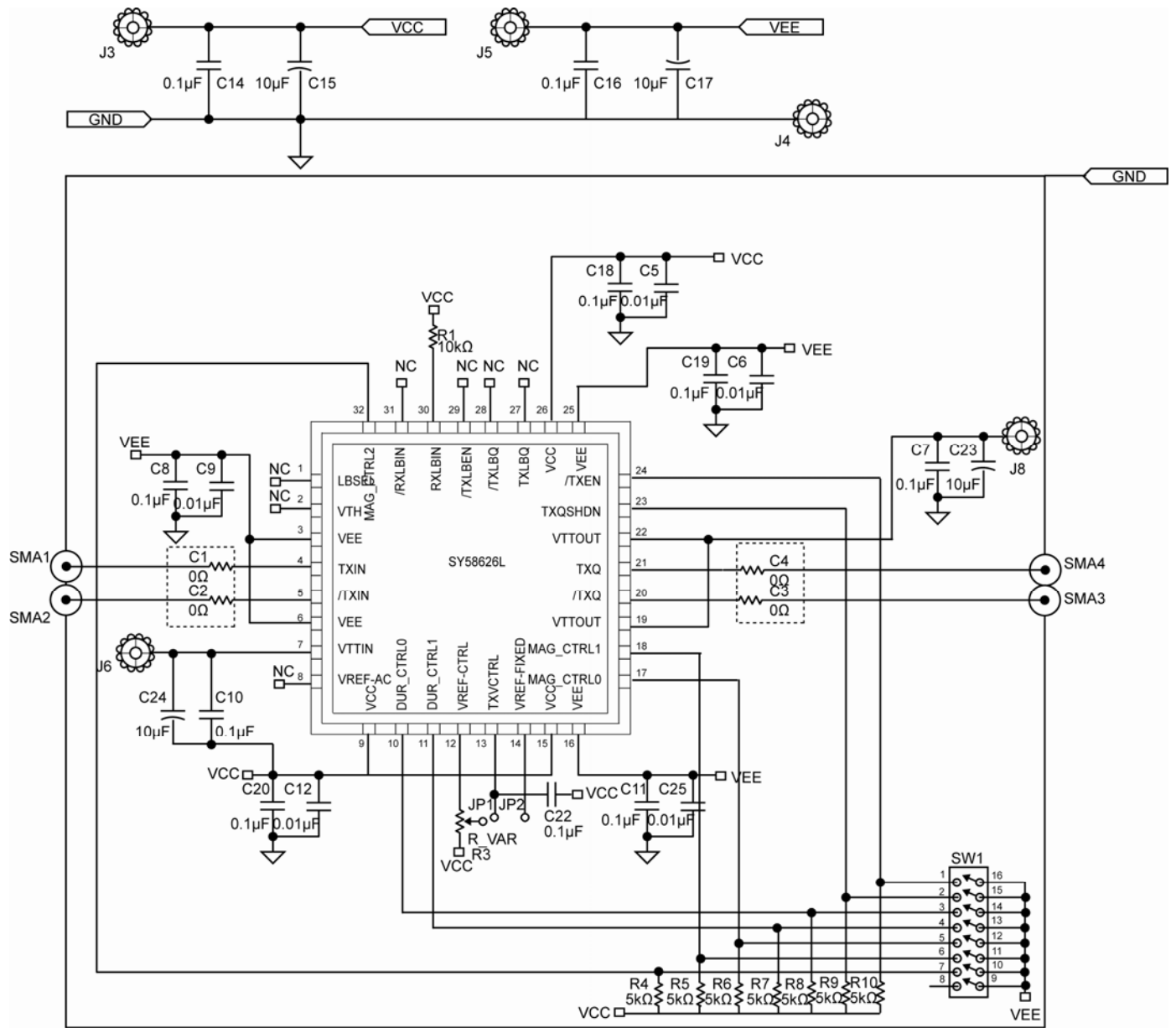

SY58626L DC-Coupled Evaluation Board

I/O	Power Supply	V _{CC}	GND	V _{EE}
DC-Coupled Input/DC-Coupled Output	3.3V	0V	0V	-3.3V

Table 1. Quick Start SY58626L DC-Coupled Evaluation Board Power Supply Connections

Evaluation Board

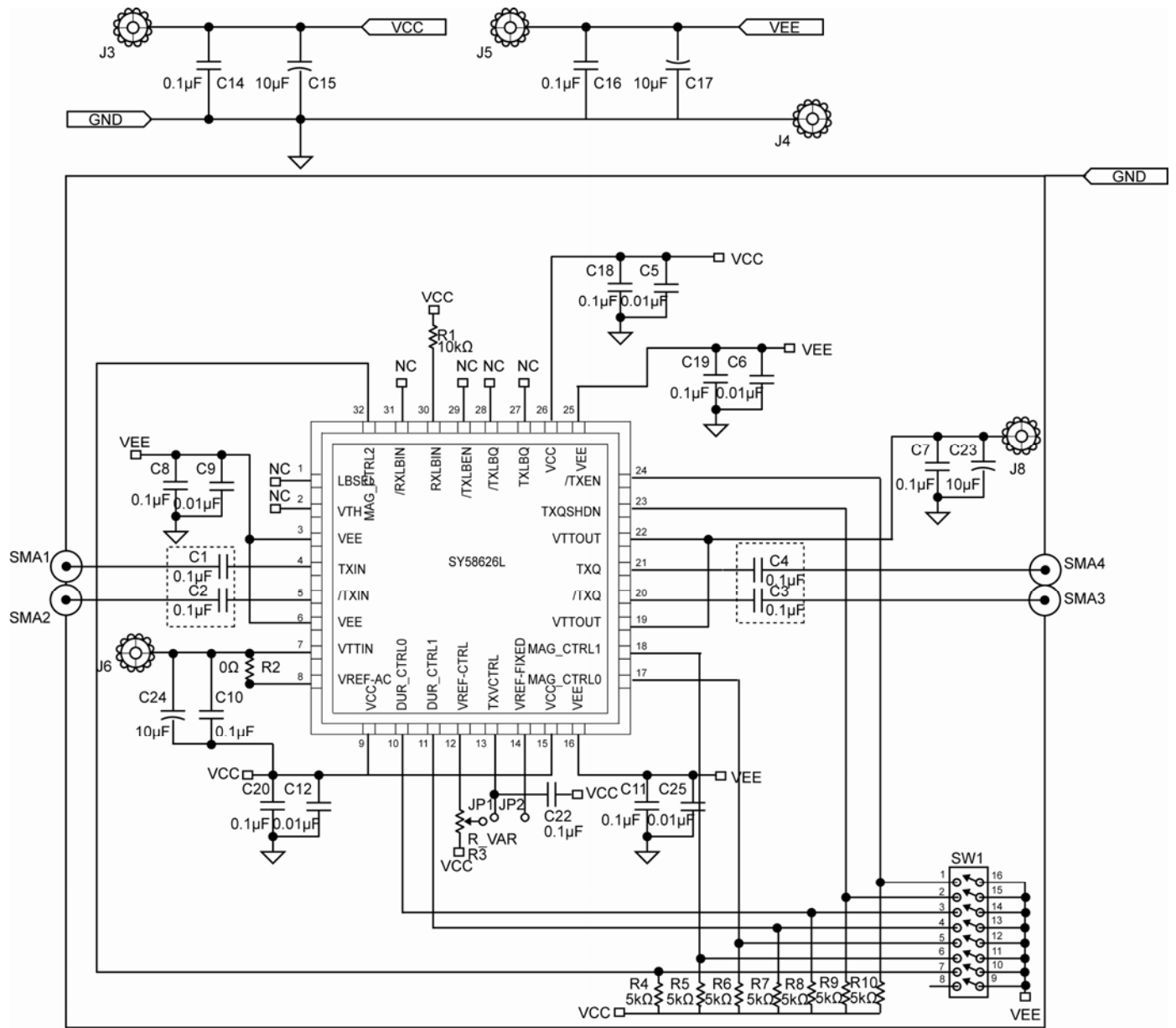

SY58626L AC-Coupled Evaluation Board

I/O	Power Supply	V _{CC}	GND	V _{EE}
AC-Coupled Input/AC-Coupled Output	3.3V	+3.3V	0V	0V

Table 2. SY58626L AC-Coupled Evaluation Board Power Supply Connections

DC-Coupled Evaluation Board Setup

Setting up the SY58626L DC-Coupled Evaluation Board

The following steps describe the quick start procedure for setting up the DC-Coupled evaluation board:

1. Set the voltage setting for a DC supply to be 3.3V and turn off the supply.
2. Connect the V_{CC} and GND terminals to the positive side of a DC power supply. This sets the 0V GND potential.
3. Connect the V_{EE} terminal to the negative side of a DC power supply.
4. Turn on the power supply and verify that the power supply current is <300mA.
5. Turn off the power supply.
6. Disable the outputs of the differential signal source and set the $V_{OH} = V_{CC} - 0.2V$ and the $V_{OL} = V_{CC} - 0.6V$.
7. Using equal length 50Ω impedance coaxial cables, connect the outputs of the signal source to the inputs of the evaluation board (SMA1 and SMA2)
8. Using equal length 50Ω impedance coaxial cables, connect the outputs of the evaluation board (SMA4 and SMA3) to the oscilloscope or other measurement device that has an internal 50Ω termination. Any of these 2 outputs that are not connected to a scope or other instrument should be terminated with a 50Ω termination to ground at the SMA on the board.
9. Turn on the power and verify the current is <400mA.
10. Enable the signal source and monitor the outputs.

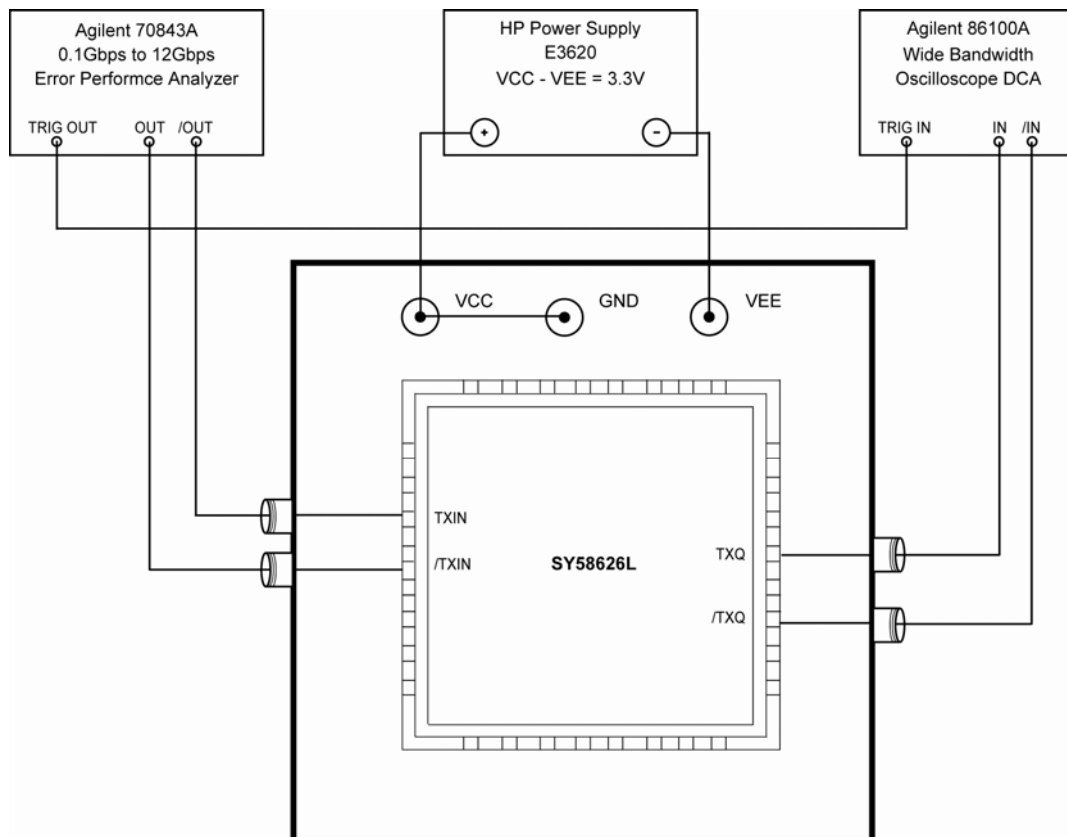

Note: Signal generator V_{OH} and V_{OL} output levels will be referenced to board GND (SY58626L VCC). V_{OH} and V_{OL} must be below VCC, and therefore set to negative voltage on the signal generator. Recommended $V_{IH} = -0.2V$, $V_{IL} = -0.6V$.

DC Evaluation Board Setup

Modifying DC-Coupled Boards for AC-Coupled Operation

Reconfiguring a DC-coupled Board into an AC-coupled Board

The following procedure details the steps for converting a DC-coupled board to an AC-coupled board:

1. Remove resistor R2.
2. Replace capacitors C1, C2, C3, and C4 with 0 Ω resistors.

Setting up the AC-coupled Evaluation Board

The following steps describe the procedure for setting up the AC-Coupled evaluation board:

1. Set the voltage setting for a DC supply to be 3.3V and turn off the supply.
2. Connect the GND and V_{EE} terminal to the negative side of a DC power supply. This is the 0V ground potential.
3. Connect the V_{CC} terminal to the positive side of a DC power supply.
4. Turn on the power supply and verify the power supply current is <300mA.
5. Turn off the power supply.
6. Using a differential signal source, set the amplitude of each side of the differential pair to be 400mV (800mV measured differentially). Set the offset to be a positive value, the value of this offset is not critical, as the AC-coupled inputs will be automatically biased to the correct offset. Turn off or disable the outputs of the signal source.
7. Using equal length 50 Ω impedance coaxial cables, connect the signal source to the inputs on the evaluation board (SMA1 and SMA2).
8. Using equal length 50 Ω impedance coaxial cables, connect the outputs of the evaluation board (SMA4 and SMA3) to the oscilloscope or other measurement device that has an internal 50 Ω termination. Any of these 2 outputs that are not connected to a scope or other instrument should be terminated with a 50 Ω -to-ground at the SMA on the board.
9. Turn on the power supply and verify the current is <400mA.
10. Enable the signal source and monitor the outputs.

Evaluation Board Layout

PC Board Layout

The evaluation board is constructed with Rogers 4003 material, is coplanar in design, fabricated to minimize noise, achieve high bandwidth, and minimize crosstalk.

L1	GND and Signal
L2	GND
L3	VCC
L4	VEE
L5	Signal
L6	GND and Signal

Table 3. Layer Stack

Bill of Materials

Item	Part Number	Manufacturer	Description	Qty.
C1-C4	CRCW04020R00F	Vishay ⁽¹⁾	0Ω, 1/16W, Resistor SMD, Size 0402	4
C5, C6, C8, C9, C11-C13	VJ0402Y010KXXA	Vishay ⁽¹⁾	0.01μF, 25V, 10% Ceramic Capacitor, Size 0402, X7R Dielectric	7
C7, C10, C15, C17- C22	VJ0402Y100KXXA	Vishay ⁽¹⁾	0.1μF, 25V, 10% Ceramic Capacitor, Size 0402, X7R Dielectric	9
C14, C16, C23, C24	293D106X0010B2T	Vishay ⁽¹⁾	10μF, 10V, Tantalum Electrolytic Capacitor, Size B	4
R4-R10	CRCW04025111F	Vishay ⁽¹⁾	5kΩ, 1/10W, 5% Thick-film Resistor, Size 0402	7
R1	CRCW04021002F	Vishay ⁽¹⁾	10kΩ, 1/10W, 5% Thick-film Resistor, Size 0402	1
R3	3269	Bourns ⁽²⁾	50kΩ Potentiometer	1
SMA1-SMA4	142-0701-851	Johnson ⁽³⁾	Jack Assembly End Launch SMA	4
J3	5005K-ND	Digi-Key ⁽⁴⁾	Color Coded PCB Test Point - Red	1
J4	5006K-ND	Digi-Key ⁽⁴⁾	Color Coded PCB Test Point - Black	1
J5-J7	5009K-ND	Digi-Key ⁽⁴⁾	Color Coded PCB Test Point - Yellow	3
SW1	CT2188LPST-ND	Digi-Key ⁽⁵⁾	8-Position Dip Switch	
U1	SY58626L	Micrel, Inc. ⁽⁵⁾	DC-to-6.4Gbps Backplane Transmit Buffer with Selectable Output Pre-emphasis, I/O DC-Offset Control, and 200mV-3.0mV _{PP} Output Swing	1

Additional Components for AC-Coupled Boards

Item	Part Number	Manufacturer	Description	Qty.
C1-C4	VJ0402Y104KXXAT	Vishay ⁽¹⁾	0.1μF, 25V, 10% Ceramic Capacitor, Size 0402, X7R Dielectric	4
R2	CRCW04020R00F	Vishay ⁽¹⁾	0Ω, 1/16W, Resistor SMD, Size 0402	1

Notes:

1. Vishay: www.vishay.com.
2. Bourns: www.bourns.com.
3. Johnson Components: www.johnsoncomponents.com.
4. Digi-Key: www.digikey.com.
5. **Micrel, Inc.:** www.micrel.com.

HBW Support

Hotline: 408-955-1690

Email Support: HBWHelp@micrel.com

Application Hints and Notes

For application notes on high-speed termination on PECL and LVPECL products, clock synthesizer products, SONET jitter measurement, and other High Bandwidth products go to Micrel's website at: <http://www.micrel.com/>. Once in Micrel's website, follow the steps below:

1. Click on "Product Info".
2. In the Applications Information Box, choose "Application Hints and Application Notes."

MICREL, INC. 2180 FORTUNE DRIVE SAN JOSE, CA 95131 USA
TEL +1 (408) 944-0800 FAX +1 (408) 474-1000 WEB <http://www.micrel.com>

The information furnished by Micrel in this data sheet is believed to be accurate and reliable. However, no responsibility is assumed by Micrel for its use. Micrel reserves the right to change circuitry and specifications at any time without notification to the customer.

Micrel Products are not designed or authorized for use as components in life support appliances, devices or systems where malfunction of a product can reasonably be expected to result in personal injury. Life support devices or systems are devices or systems that (a) are intended for surgical implant into the body or (b) support or sustain life, and whose failure to perform can be reasonably expected to result in a significant injury to the user. A Purchaser's use or sale of Micrel Products for use in life support appliances, devices or systems is a Purchaser's own risk and Purchaser agrees to fully indemnify Micrel for any damages resulting from such use or sale.

© 2006 Micrel, Incorporated.