



SY89251V Evaluation Board

Enhanced Differential Receiver

General Description

The SY89251V evaluation board is designed for convenient set-up and quick evaluation. It allows the user to evaluate the part over the full voltage-range without requiring any modification to the board.

The evaluation board standard configuration is AC-coupled input with AC-coupled outputs for direct interface to a 50Ω-compatible oscilloscope. For applications that require a DC-coupled configuration, step-by-step instructions for modifying the board are included.

All datasheets and support documentation can be found at Micrel's web site at: www.micrel.com.

Features

- SY89251VM, /Q PECL output
- SY89251VM, Q_{HG}, /Q_{HG} PECL output
- Single 3.3V or 5V power supply
- AC-coupled configuration for ease-of-use
- I/O interface includes on-board termination
- Fully assembled and tested
- Reconfigurable for DC-coupled operation

Applications

- SY89251V Enhanced Differential Receiver

Evaluation Board

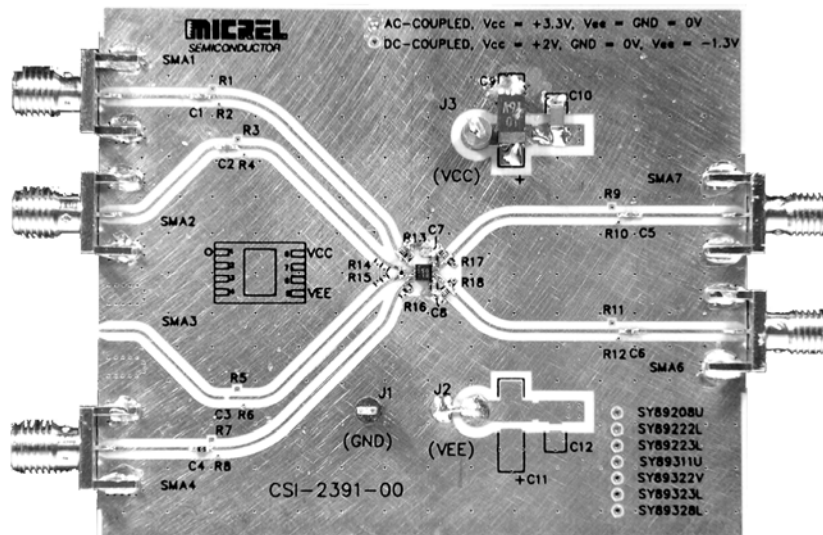

Evaluation Board Description

The SY89251V evaluation board is designed to accept an AC-coupled input with AC-coupled or DC-coupled outputs.

The choice between the two configurations offers the user flexibility in selecting the board that is right for the given application.

Step-by-step instructions for modifying an AC-coupled evaluation board for DC-coupled operation are supplied in the sub-section "Modifying your AC-Coupled Board for DC-Coupled Operation."

AC-Coupled Evaluation Board (AC-Coupled Input, AC-Coupled Output)

The AC-coupled configuration is suited for most customer applications and is preferred by the majority of users because of its ease-of-use. It requires only a single power supply and offers the most flexibility when interfacing to a variety of signal sources.

The DC-bias levels and AC-coupling capacitors are supplied on-board for the input. The user only needs to supply a minimum input voltage swing and the bias voltage will automatically adjust the input to the correct level as the power supply voltage varies.

DC-Coupled Evaluation Board (AC-Coupled Input, DC-Coupled Output)

For DC-coupled operation, the boards can be modified to use two power supplies in a "split-supply configuration". The SY89251V operates with a 3.3V or 5V supply. The term split-supply simply means a +3.3V supply is split into +2V and -1.3V, and a +5V supply is split into +2V and -3.0V. This effectively offsets the board by +2V. The +2V offset in this two-power supply configuration then provides the correct terminations for the device by setting the ground potential on the board to be exactly 2 volts below the V_{CC} supply. The V_{EE} voltage is then set to -1.3V for a 3.3V V_{CC} , and -3.0V for a 5V V_{CC} so that the device power pin still sees a full 3.3V or 5V potential between V_{CC} and V_{EE} .

Step-by-step instructions for modifying an AC-coupled evaluation board for DC-coupled operation are supplied in the sub-section, "Modifying your AC-Coupled Board for DC-Coupling Operation."

AC-Coupled Evaluation Board Setup (AC-Coupled Input, AC-Coupled Output)

Setting up the SY89251V AC-Coupled Evaluation Board

The following steps describe the procedure for setting up the evaluation board:

1. Set the voltage setting for a DC supply to be 3.3V or 5V and turn off the supply. If 3.3V, set R13, R17, and R18 to 100 Ω . If 5V, set resistor values to 180 Ω .
2. On the evaluation board, short the GND terminal to the V_{EE} terminal and connect them to the negative side of the DC power supply.
3. Connect the V_{CC} terminal to the positive side of the DC power supply.
4. Turn on the power supply and verify that the power supply current is <60mA.
5. Turn off the power supply.
6. Using a signal source, set the amplitude to be 800mV. The offset is not critical, as the AC-coupled inputs will be automatically biased to the correct offset. Turn off or disable the outputs of the signal source.
7. To enable the QHG, /QHG output, hardwire SMA4 to V_{CC} . If the QHG, /QHG output is to be disabled, leave SMA4 open.

EN	QHG Output
0	Logic Low
1	Data

Table 1. Output Enable/Disable

8. Using a 50 Ω impedance coaxial cable connect the signal source to the SMA input on the evaluation board.
9. Using equal length 50 Ω impedance coaxial cables connect the QHG, /QHG and /Q outputs of the evaluation board to the oscilloscope or other measurement device that has an internal 50 Ω termination. Terminate all unused outputs into 50 Ω .
10. Turn on the power and verify the current is <60mA.
11. Enable the signal source and monitor the outputs.

Evaluation Board

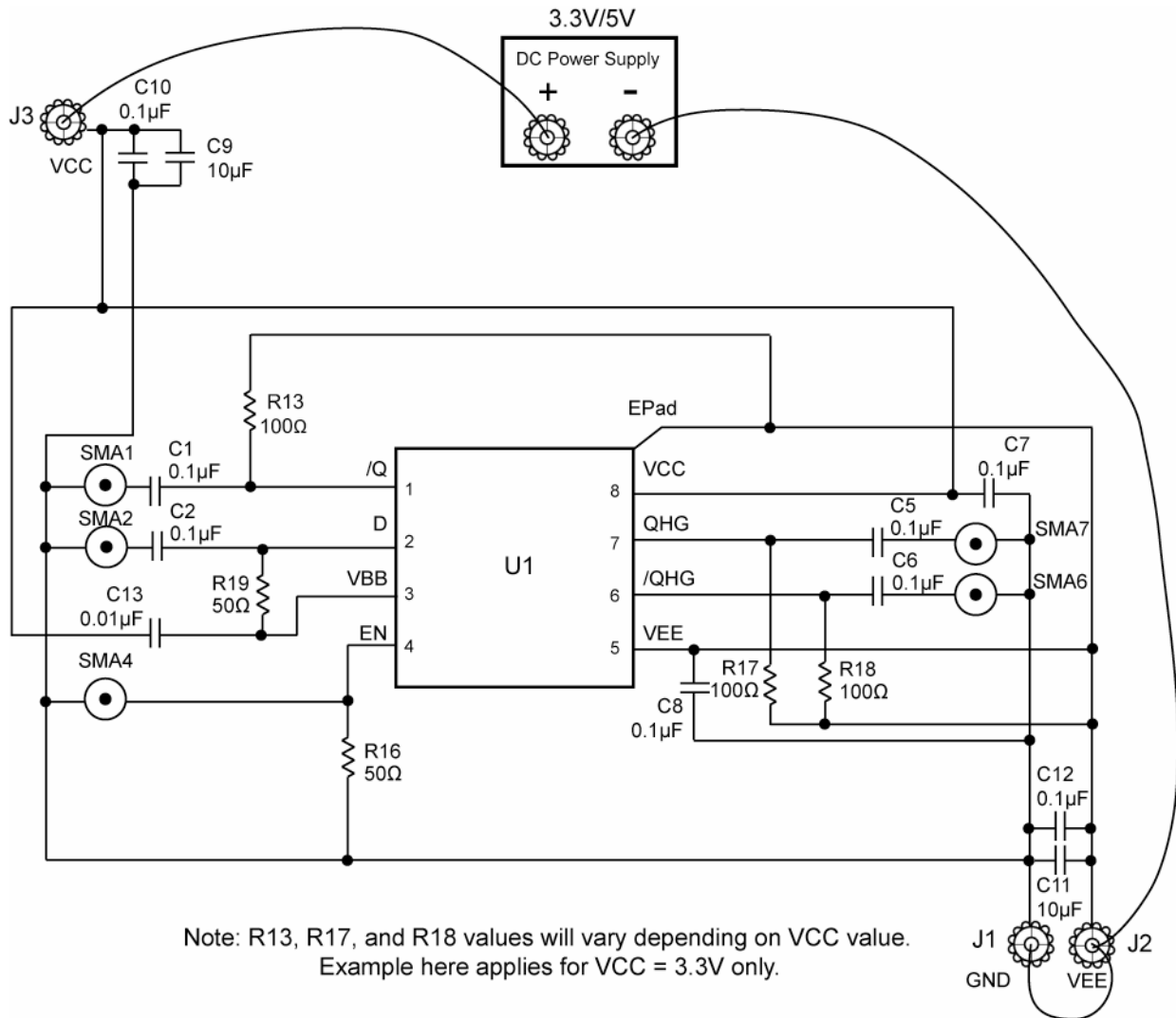

SY89251V AC-Coupled Evaluation Board

Power Supply	V _{CC}	GND	V _{EE}	I/O
3.3V	3.3V	0V	0V	AC-Coupled Input/AC-Coupled Output
5V	5V	0V	0V	AC-Coupled Input/AC-Coupled Output

Table 2. SY89251V AC-Coupled Evaluation Board Power Supply Connections

Modifying the AC-Coupled Board for DC-Coupled Operation

When DC-Coupling is Necessary

For applications where AC-coupling of the output is not appropriate, the board can be reconfigured for DC-coupled output operation. The inputs remain AC-coupled.

Reconfiguring AC-Coupled Outputs to be DC-Coupled Outputs

The following procedure details the steps for converting an AC-coupled board to a DC-coupled board.

1. Replace capacitors C1, C5, and C6 with 0 Ω resistors.
2. Remove R13, R17, and R18.

Setting up the SY89251V DC-Coupled Evaluation Board (AC-Coupled Input, DC-Coupled Output)

The following steps describe the procedure for setting up the ECL-output evaluation board:

1. Set the voltage for DC supply number 1 to be 2V and connect the positive side to V_{CC} .
2. Set the voltage for DC supply number 2 to be 1.3V or 3V for 3.3V or 5V supplies, respectively, and connect the negative side to V_{EE} .
3. Connect the negative side of power supply 1 to the positive side of power supply 2. This is the 0V ground potential for the board.
4. Turn off the power supplies and connect the GND terminal on the board to the negative side of DC power supply 1 and the positive side of DC power supply 2.

5. Verify that the power supply current is <60mA.
6. Turn off the power supply.
7. Using a signal source, set the amplitude to be 800mV. The offset is not critical, as the AC-coupled inputs will be automatically biased to the correct offset. Turn off or disable the outputs of the signal source.
8. To enable the QHG, /QHG output, hardwire SMA4 to V_{CC} . If the QHG, /QHG output is to be disabled, tie SMA4 to V_{EE} . Leaving SMA4 open may not disable the part depending on the V_{EE} voltage setting. See Table 1.
9. Using a 50 Ω impedance coaxial cable, connect the signal source to the SMA input on the evaluation board.
10. Using equal length 50 Ω impedance coaxial cables connect the QHG, /QHG and /Q outputs of the evaluation board to the oscilloscope or other measurement device that has an internal 50 Ω termination.
11. Turn on the power and verify the current is <60mA.
12. Enable the signal source and monitor the outputs.

Evaluation Board

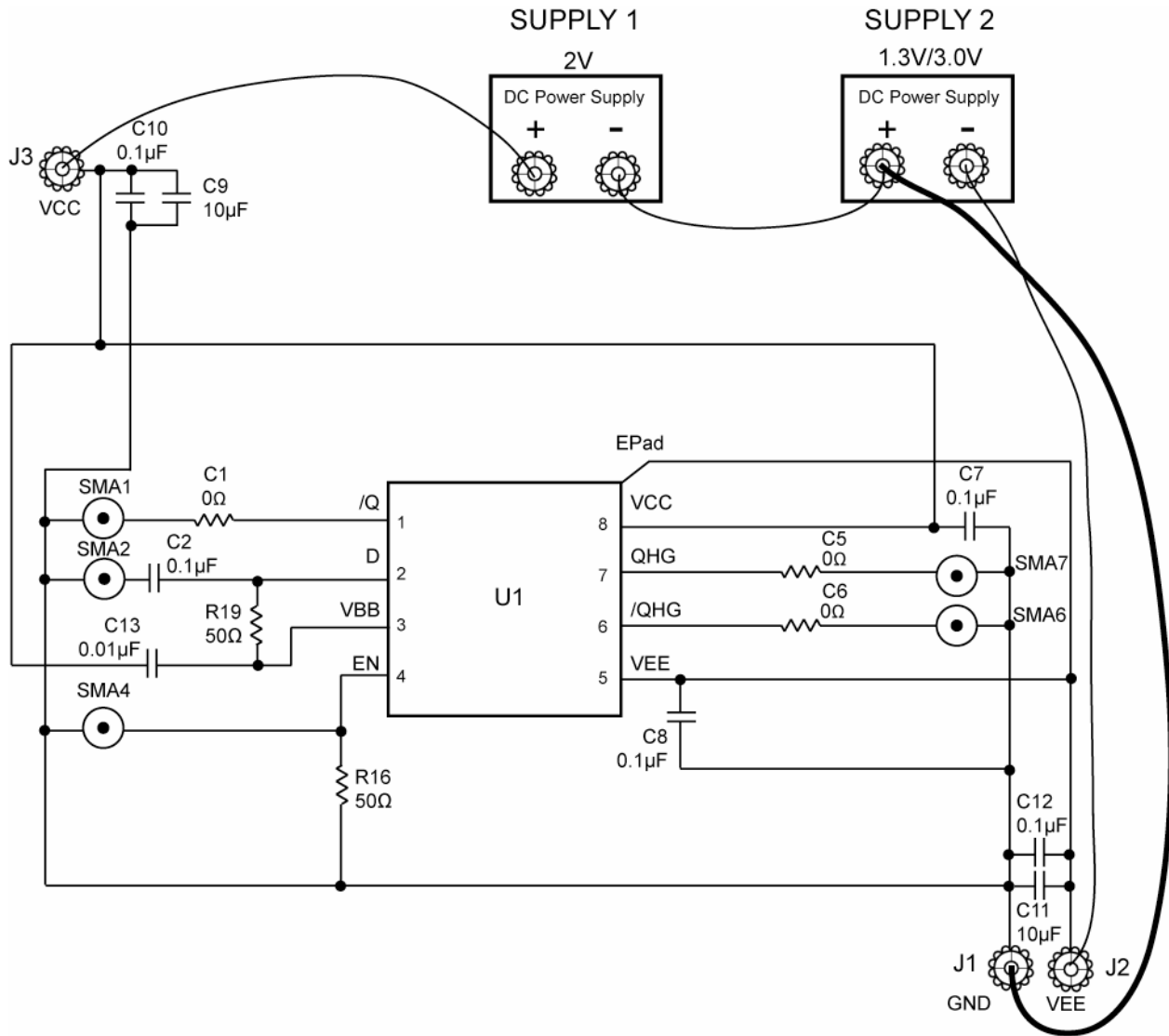

SY89251V DC-Coupled Evaluation Board

Power Supply	V _{CC}	GND	V _{EE}	I/O
3.3V	2V	0V	-1.3V	AC-Coupled Input/DC-Coupled Output
5V	2V	0V	-3V	AC-Coupled Input/DC-Coupled Output

Table 3. SY89251V DC-Coupled Evaluation Board Power Supply Connections

Bill of Materials

SY89251V Evaluation Board

Item	Part Number	Manufacturer	Description	Qty.
C1, C2, C5, C6	VJ0402Y104KXXAT	Vishay ⁽¹⁾	0.1 μ F, 25V, 10% Ceramic Capacitor, Size 0402, X7R Dielectric	4
C9, C11	293D106X0010	Vishay ⁽¹⁾	10 μ F, 20V, Tantalum Electrolytic Capacitor, Size C	2
C7, C8	VJ0402Y104KXXAT	Vishay ⁽¹⁾	0.1 μ F, 25V, 10% Ceramic Capacitor, Size 0402, X7R Dielectric	2
C10, C12	VJ0805Y104KXXAT	Vishay ⁽¹⁾	0.1 μ F, 25V, 10% Ceramic Capacitor, Size 0805	2
C13	VJ0402Y103KXXAT	Vishay ⁽¹⁾	0.01 μ F, 25V, 10% Ceramic Capacitor, Size 0402	1
C4	CRCW040200R0F	Vishay ⁽¹⁾	Add 0 Ω , 1/16W, 5% Thick-film Resistor, Size 0402	1
R16, R19	CRCW04020500F	Vishay ⁽¹⁾	50 Ω , 1%, Resistor, Size 0402	2
R13, R17, R18	CRCW0402820F	Vishay ⁽¹⁾	100 Ω , 1/16W, 5% Thick-film Resistor, Size 0402	3
J3			Red Test Point (V _{CC})	1
J1			Black Test Point (GND)	1
J2			Yellow Test Point (V _{EE})	1
SMA1, SMA2, SMA4, SMA6, SMA7	142-0701-851	Johnson Components ⁽²⁾	Jack Assembly End Launch SMA	5
U1	SY89251V	Micrel ⁽³⁾	Enhanced Differential Receiver	1

Additional Bill of Materials for SY89251V DC-Coupled Evaluation Board

Item	Part Number	Manufacturer	Description	Qty.
C1, C5, C6	CRCW040200R0F	Vishay ⁽¹⁾	Add 0 Ω , 1/16W, 5% Thick-film Resistor, Size 0402	3

Notes:

1. Vishay: www.vishay.com.
2. Johnson Components: www.johnsoncomponents.com.
3. Micrel, Inc.: www.micrel.com.

PC Board Layout

Board Layout

The evaluation boards are constructed with Rogers 4003 material fabricated to minimize noise, achieve high bandwidth and minimize crosstalk.

Layer	
L1	GND and Signal
L2	GND
L3	V _{CC} and V _{EE}
L4	GND and Signal

Table 4. Layer Stack

HBW Support

Hotline: 408-955-1690

Email Support: HBWHelp@micrel.com

Application Hints and Notes

For application notes on high speed termination on PECL and LVPECL products, clock synthesizer products, SONET jitter measurement, and other High Bandwidth product go to Micrel Inc., website at <http://www.micrel.com/>. Once in Micrel's website, follow the steps below:

1. Click on "Product Info".
2. In the Applications Information Box, choose "Application Hints and Application Notes."

MICREL, INC. 2180 FORTUNE DRIVE SAN JOSE, CA 95131 USA
 TEL +1 (408) 944-0800 FAX +1 (408) 474-1000 WEB <http://www.micrel.com>

The information furnished by Micrel in this data sheet is believed to be accurate and reliable. However, no responsibility is assumed by Micrel for its use. Micrel reserves the right to change circuitry and specifications at any time without notification to the customer.

Micrel Products are not designed or authorized for use as components in life support appliances, devices or systems where malfunction of a product can reasonably be expected to result in personal injury. Life support devices or systems are devices or systems that (a) are intended for surgical implant into the body or (b) support or sustain life, and whose failure to perform can be reasonably expected to result in a significant injury to the user. A Purchaser's use or sale of Micrel Products for use in life support appliances, devices or systems is a Purchaser's own risk and Purchaser agrees to fully indemnify Micrel for any damages resulting from such use or sale.

© 2009 Micrel, Incorporated.