

2-Wire Serial I/O Expander & Fan Controller

The MIC74 is a fully programmable serial-to-parallel I/O expander compatible with I²C™ and SMBus™. Each of its eight I/Os can be programmed as an input or output. Each output can be programmed as open-drain or complementary push-pull. The I/O's are "5V-tolerant" and can be pulled above V_{DD} (<=5.5V)! Voltage tolerant I/Os greatly simplify interfacing in multiple-supply and power managed systems. If desired, the four most significant I/O bits can be programmed to implement fan speed control. An internal clock generator and state machine eliminate the overhead generally associated with "bit-banging" fan control. This functionality is transparent if not needed.

All seven internal registers can be read by the host. Output bits are capable of directly driving high-current loads such as LEDs. A separate interrupt output can notify the host of state changes on the input bits without requiring the MIC74 to perform a transaction on the serial bus or be polled by the host. Each interrupt source is individually maskable and has a corresponding status bit to support polling. Three address inputs allow up to eight devices to share the same bus and provide a total of 64 bits of I/O. The MIC74 is available in an ultra-small footprint 16-pin QSOP package. Low quiescent current, small size, and low package height make the MIC74 ideal for portable and desktop applications.

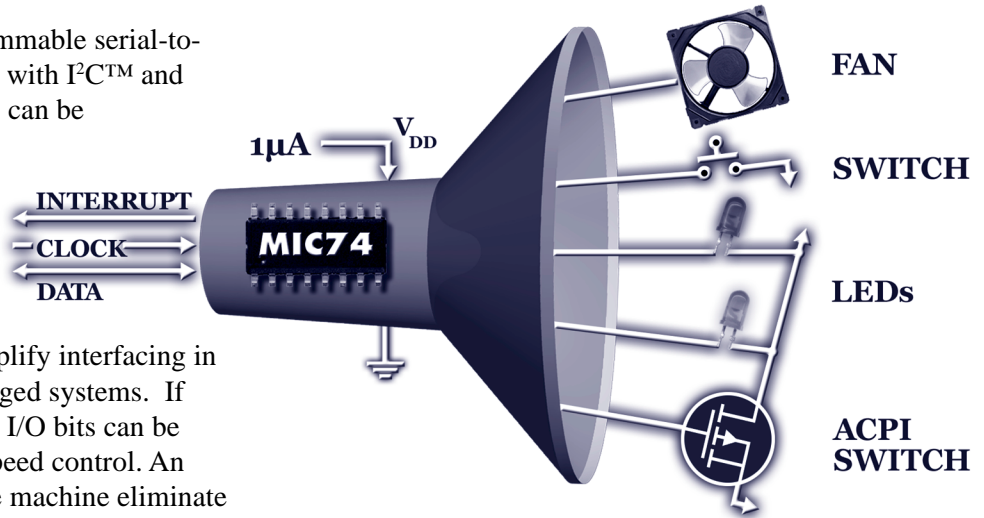

Features

- ◆ Provides eight bits of general purpose I/O
- ◆ SMBus/I²C compatible interface with /ALERT signal
- ◆ Bit programmable options:
 - Direction: input or output
 - Output: push-pull or open-drain
- ◆ Outputs can directly drive LEDs
- ◆ Supports polling and/or interrupts
- ◆ Built-in fan speed control logic (optional)
- ◆ 2.7V – 3.6V operating voltage range
- ◆ 5V tolerant I/O
- ◆ Low quiescent current: 2µA (typical)
- ◆ Up to 8 devices can share the same bus

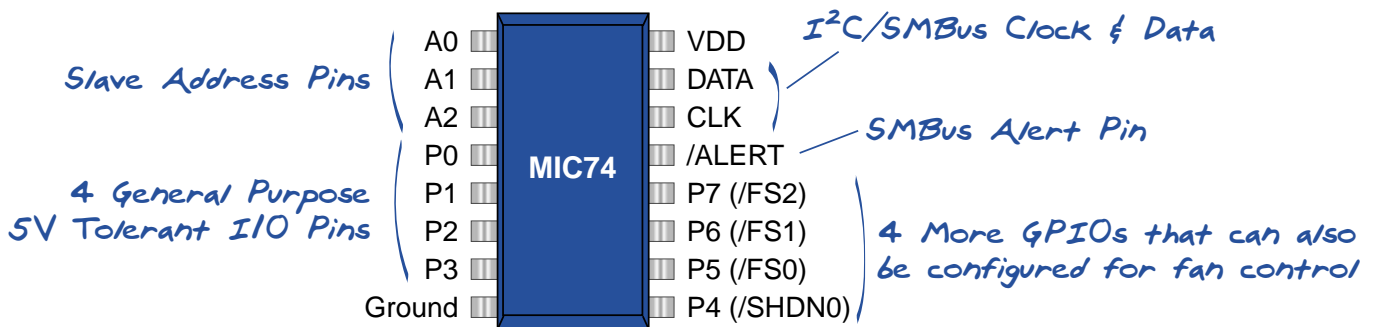

SMBus™ is a trademark of Intel Corporation. I²C™ is a trademark of Philips Electronics N.V.

MIC74 Fan Control

The MIC74's optional fan control feature is uniquely flexible and scalable, but also easy to implement, requiring a minimum of added hardware and software. When the MIC74's Fan Mode is activated, four of the I/O pins are used to control an external linear regulator, switcher, or discrete circuit and provide eight different fan speeds. The host software simply writes the desired fan speed into the fan speed register, and the MIC74 does the rest. An internal start-up timer insures clean fan starts.

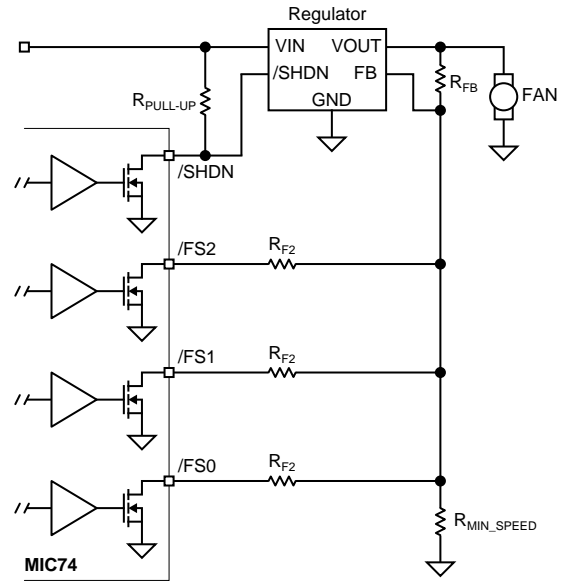

Fan Speed Control Application

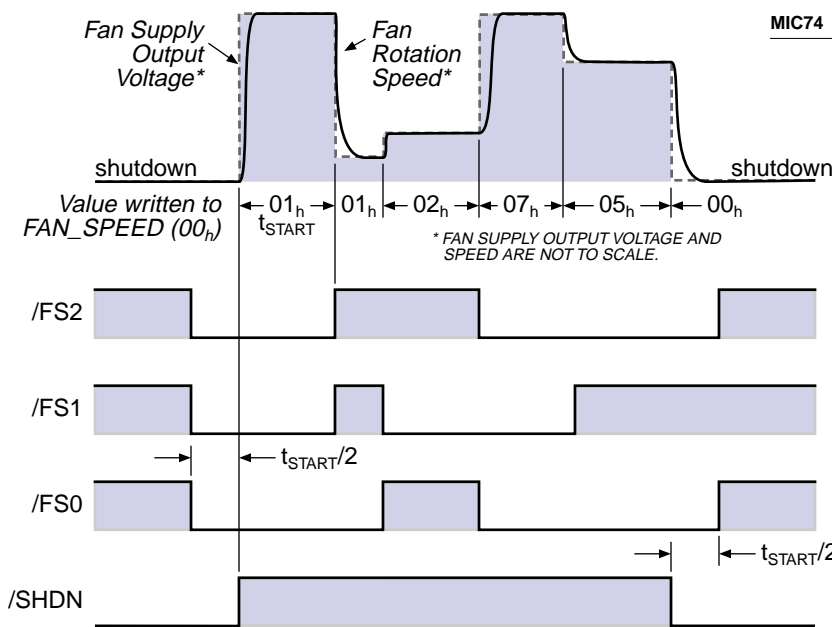

Fan-Mode Timing and System Behavior

SMBus is a trademark of Intel Corporation. PC is a trademark of Philips Electronics, N.V.

Contact Micrel Semiconductor

Corporate HQ, USA

1849 Fortune Drive
San Jose,
CA 95131 USA
Tel: +1 (408) 944-0800
Fax: +1-408-944-0970

Micrel Eastern USA

93 Branch Street
Medford, NJ 08055 USA
Tel: +1 (609) 654-0078
Fax: +1 (609) 546-0989

Micrel Central USA

8402 Sterling Suite 101
Irving, TX 75063 USA
Tel: +1 (972) 929-0051
Fax: +1 (972) 915-0120

Micrel Western USA

3250 Scott Blvd.
Santa Clara, CA 95054 USA
Tel: +1 (408) 914-7670
Fax: +1 (408) 914-7878

Micrel Northwest USA

401 NE Ravenna Blvd. Box 152
Seattle, WA 98115 USA
Tel: +1 (206) 526-7299
Fax: +1 (206) 526-8829

Micrel Southwest USA

7545 Irvine Center Dr. Suite 200
Irvine, CA 92618 USA
Tel: +1 (949) 623-8433
Fax: +1 (949) 623-8305

Micrel Semiconductor Asia

4F, Jinsol Building
826-14, Yeoksam-dong
Kangnam-ku
Seoul 135-080 Korea
Tel: +82 (2) 3466-3000
Fax: +82 (2) 3466-2999

Micrel Semiconductor Taiwan

12F-10, No. 237
Sec. 2, Fu-Hsing South Road
Taipei, Taiwan, R.O.C.
Tel: +886 (2) 2705-4976
Fax: +886 (2) 2705-4977

Micrel Semiconductor Japan

1-16-15 Dogenzaka, Shibuyaku
Tokyo 150-0043 Japan
Tel: +81 (3) 5428-0871
Fax: +81 (3) 5428-0872

Micrel Semiconductor Europe

1st Floor, 3 Lockside Place
Mill Lane
Newbury, Berks RG14 5QS
United Kingdom
Tel: +44 1635-524455
Fax: +44 1635 524466

Worldwide Web

<http://www.micrel.com>

Literature Requests

USA +1(800) 401-9572

MICREL
The Infinite Bandwidth Company™