



**MICREL**®

Innovation Through Technology™

## **Ethernet Applications**

# Stand Alone Un-Managed Switch

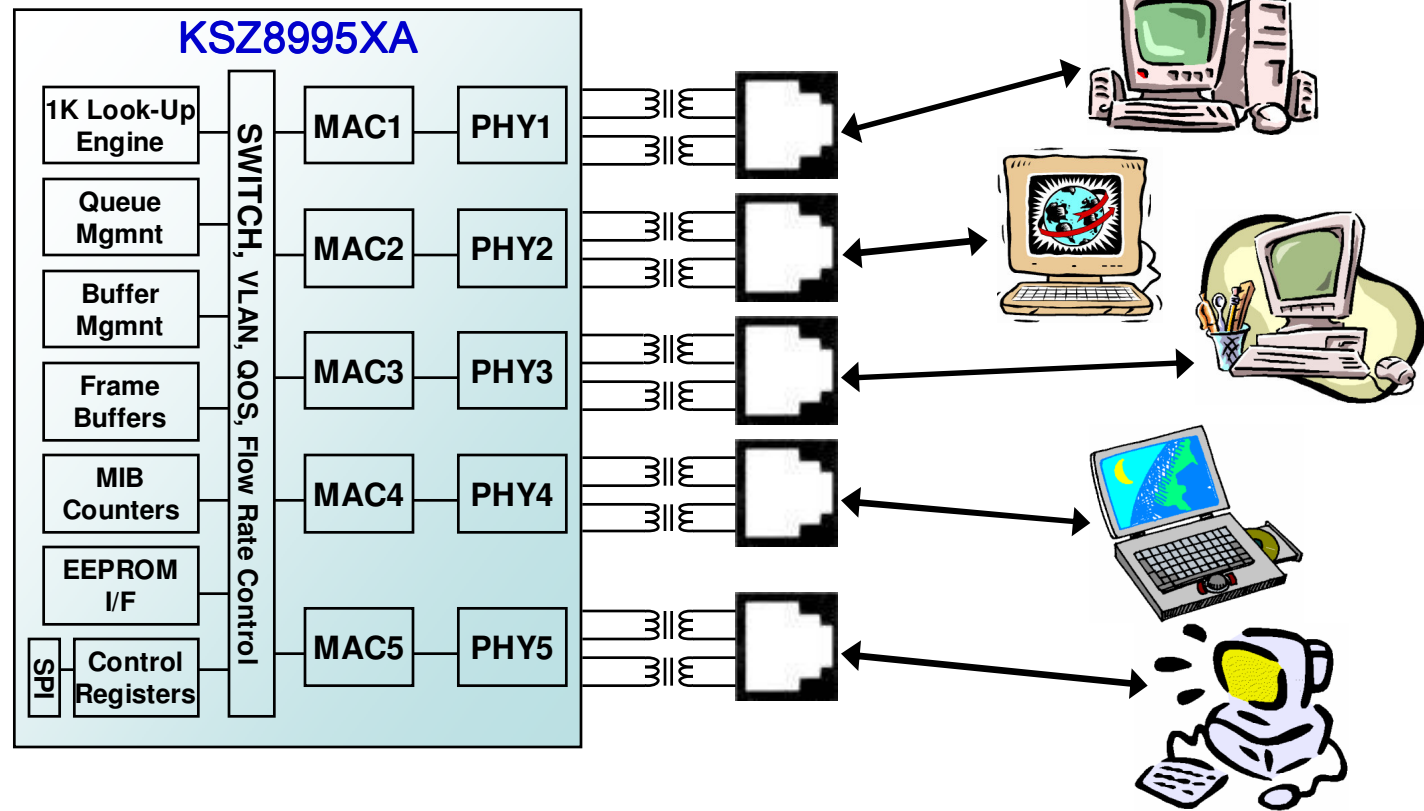

# Stand Alone Managed Switch

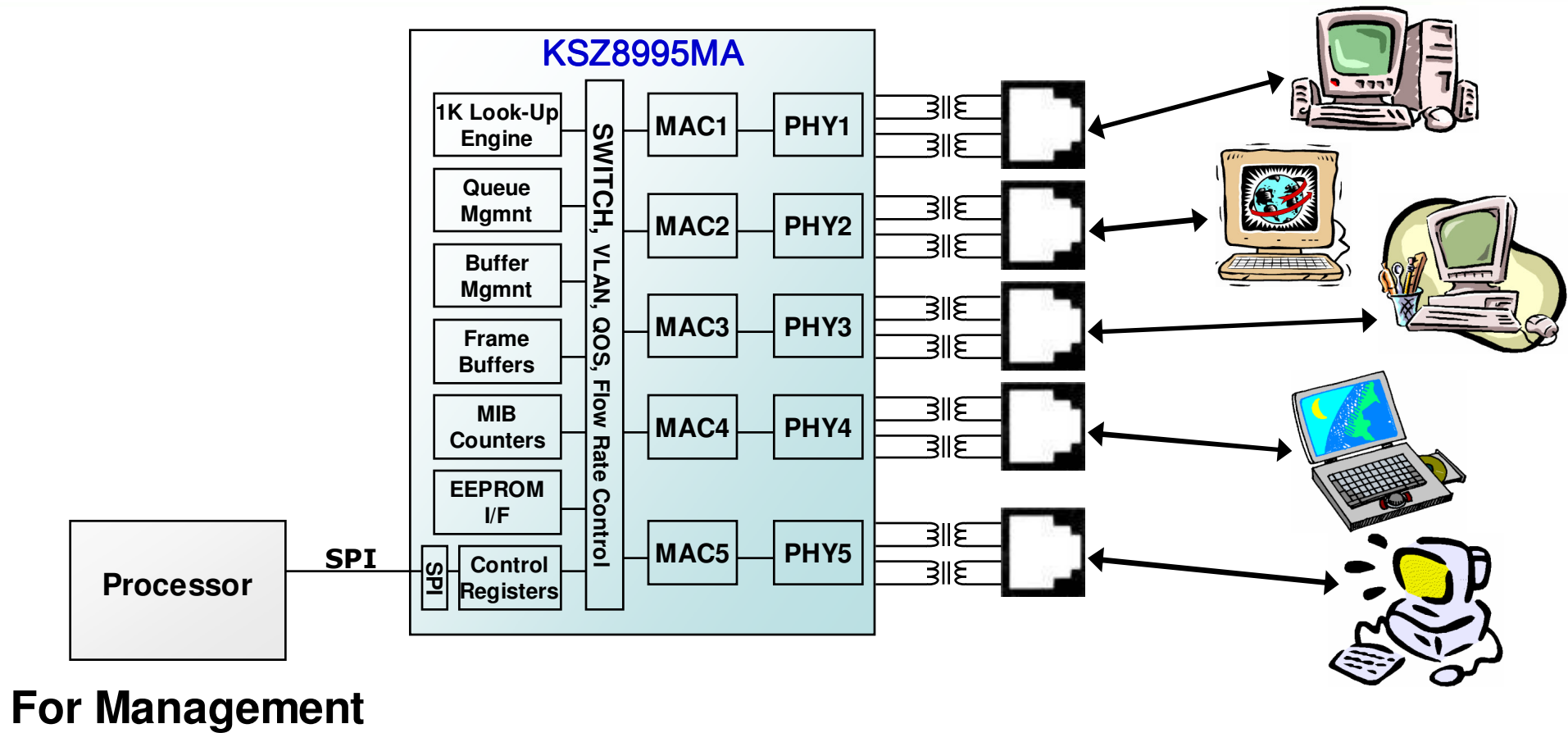

# Residential Gateway Box

## Residential Gateway Box

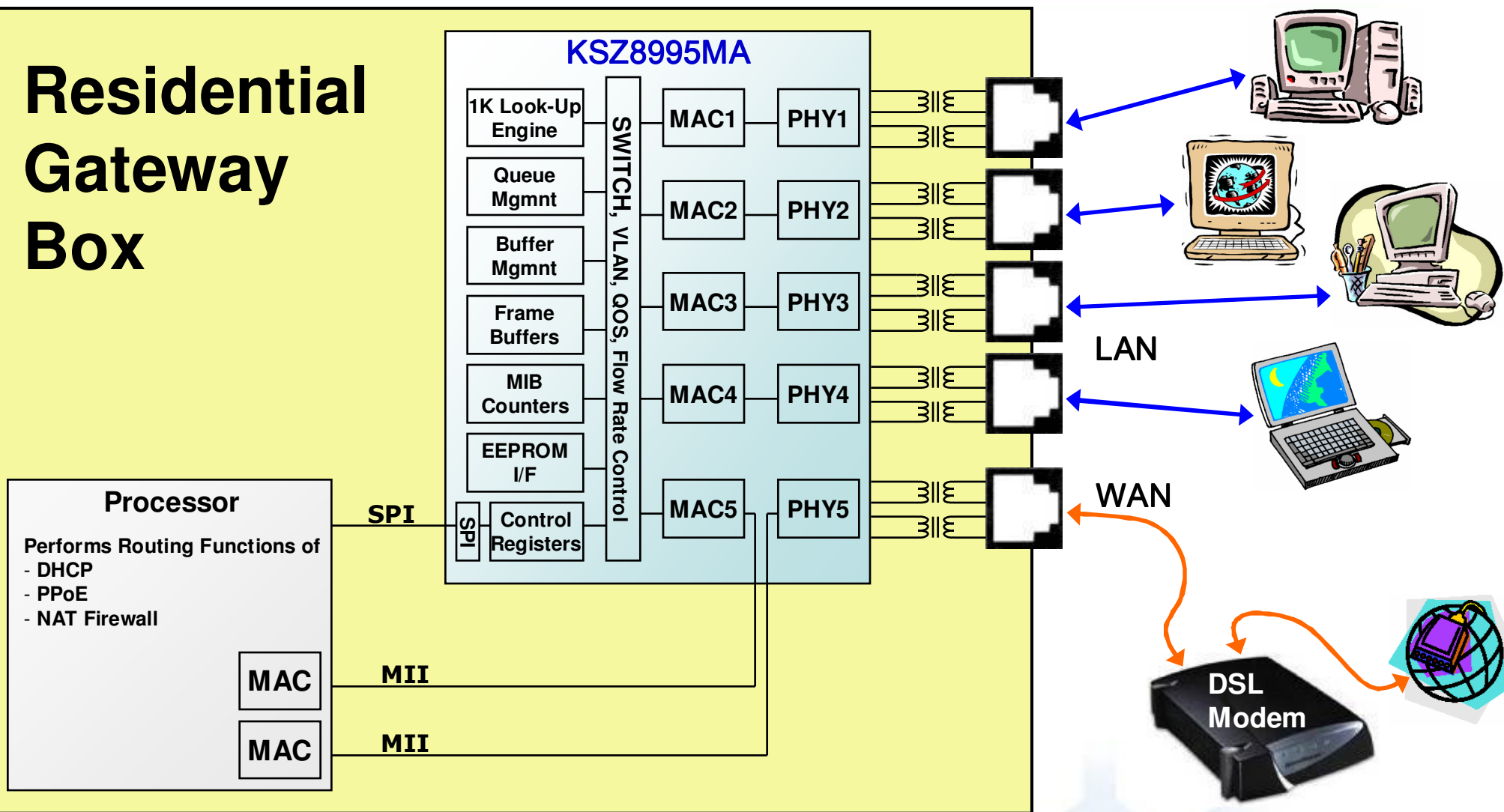

# Dual Media Converter

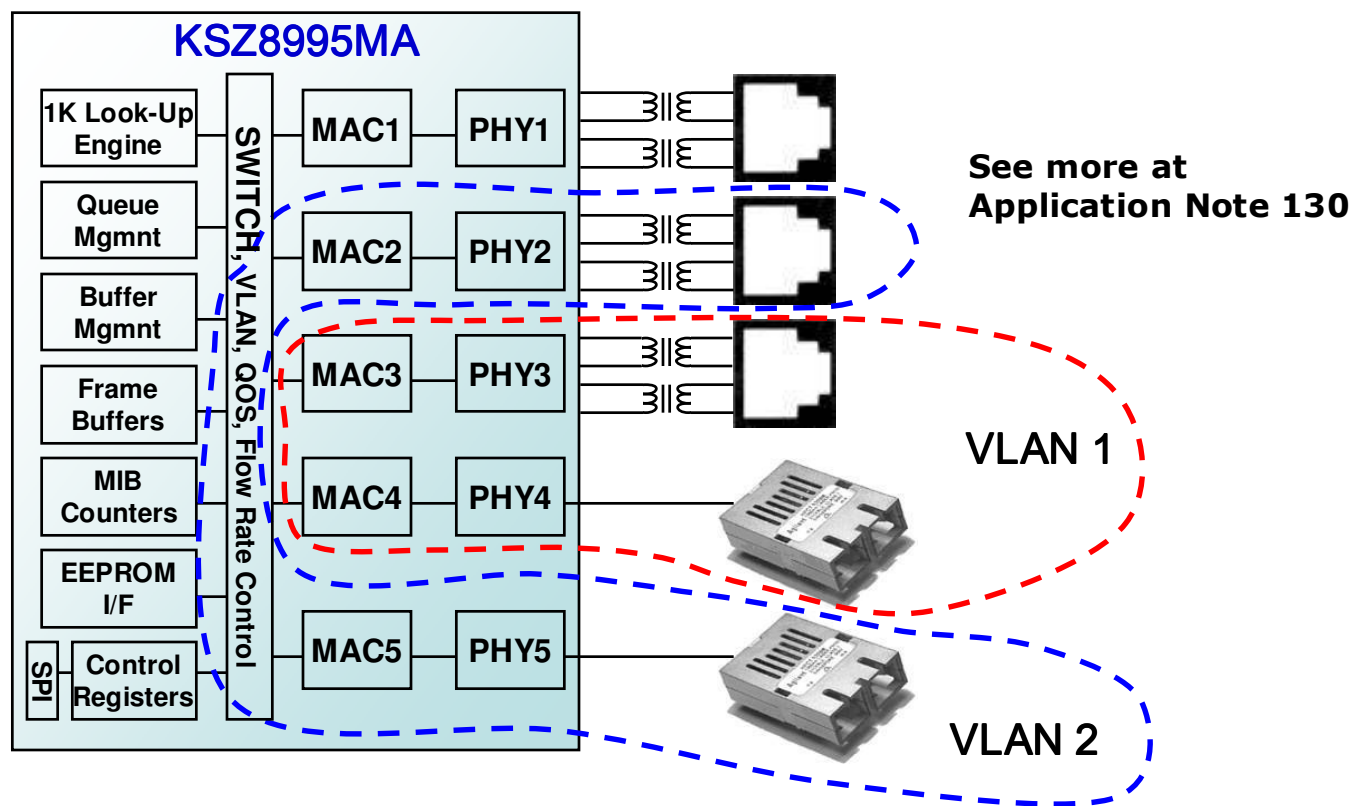

Using VLAN's allows for independent networks  
- Used to create redundant rings, Industrial Applications

# Simple 16 port Switch

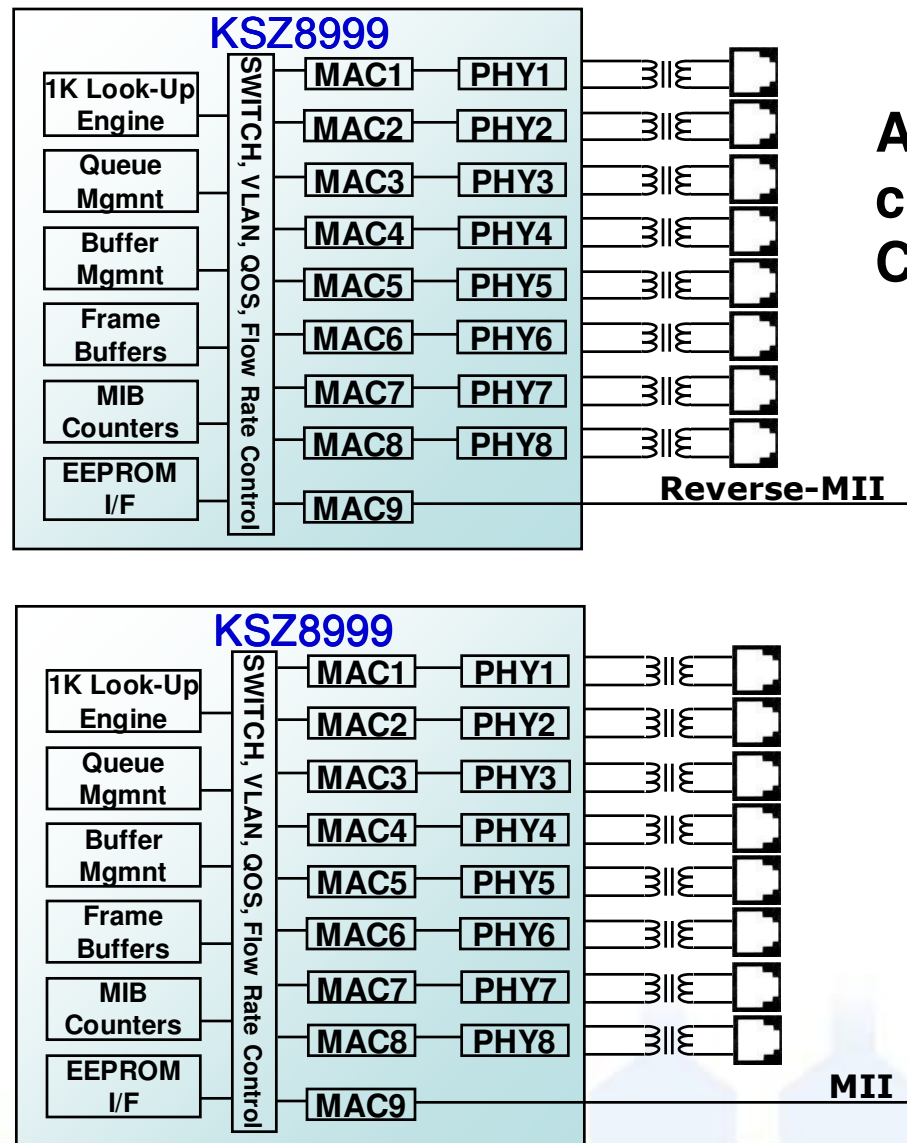

All ports may be configured as Copper or Fiber

# Capacitively Coupled Backplane

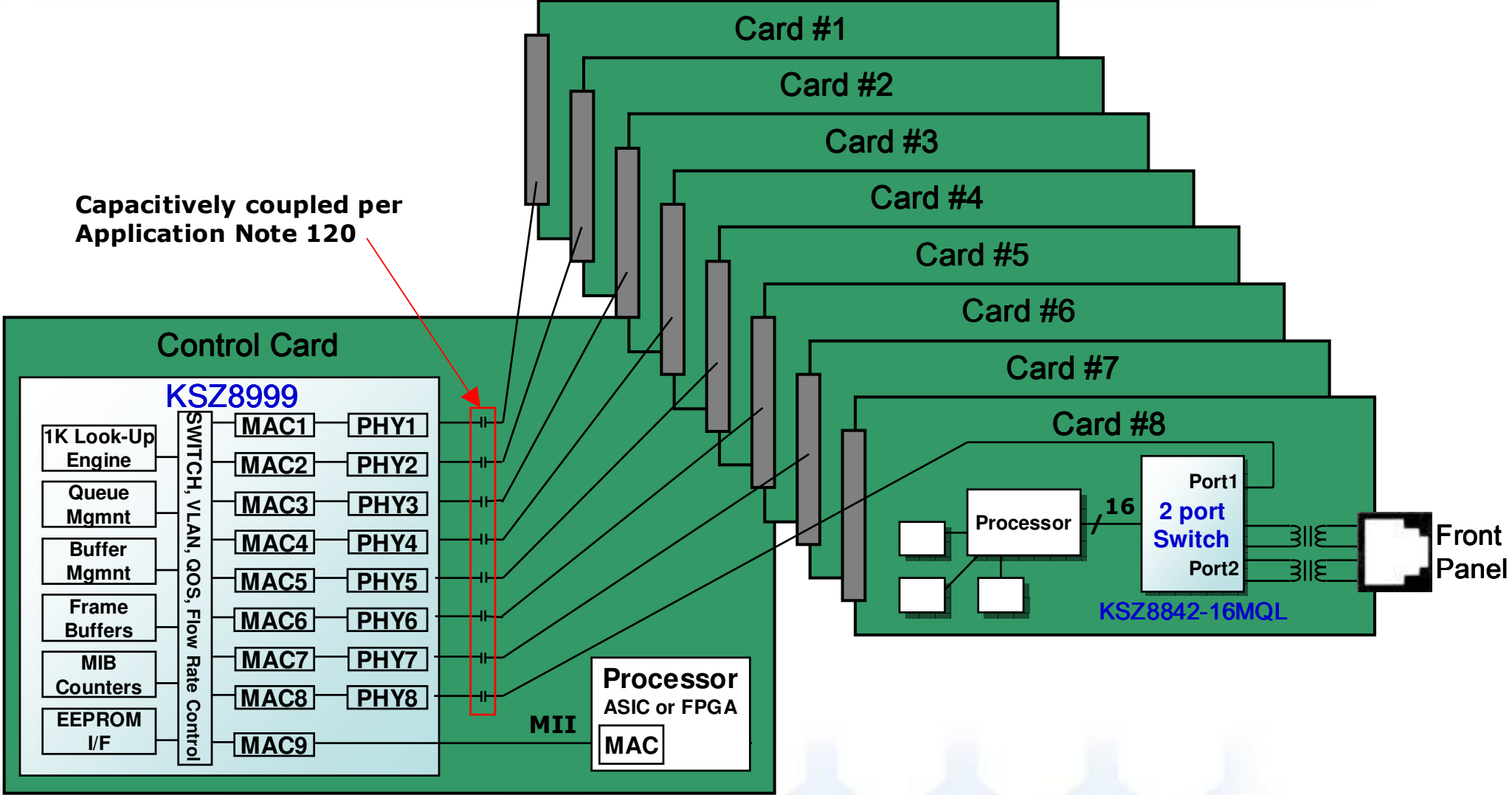

# Managed Industrial Router

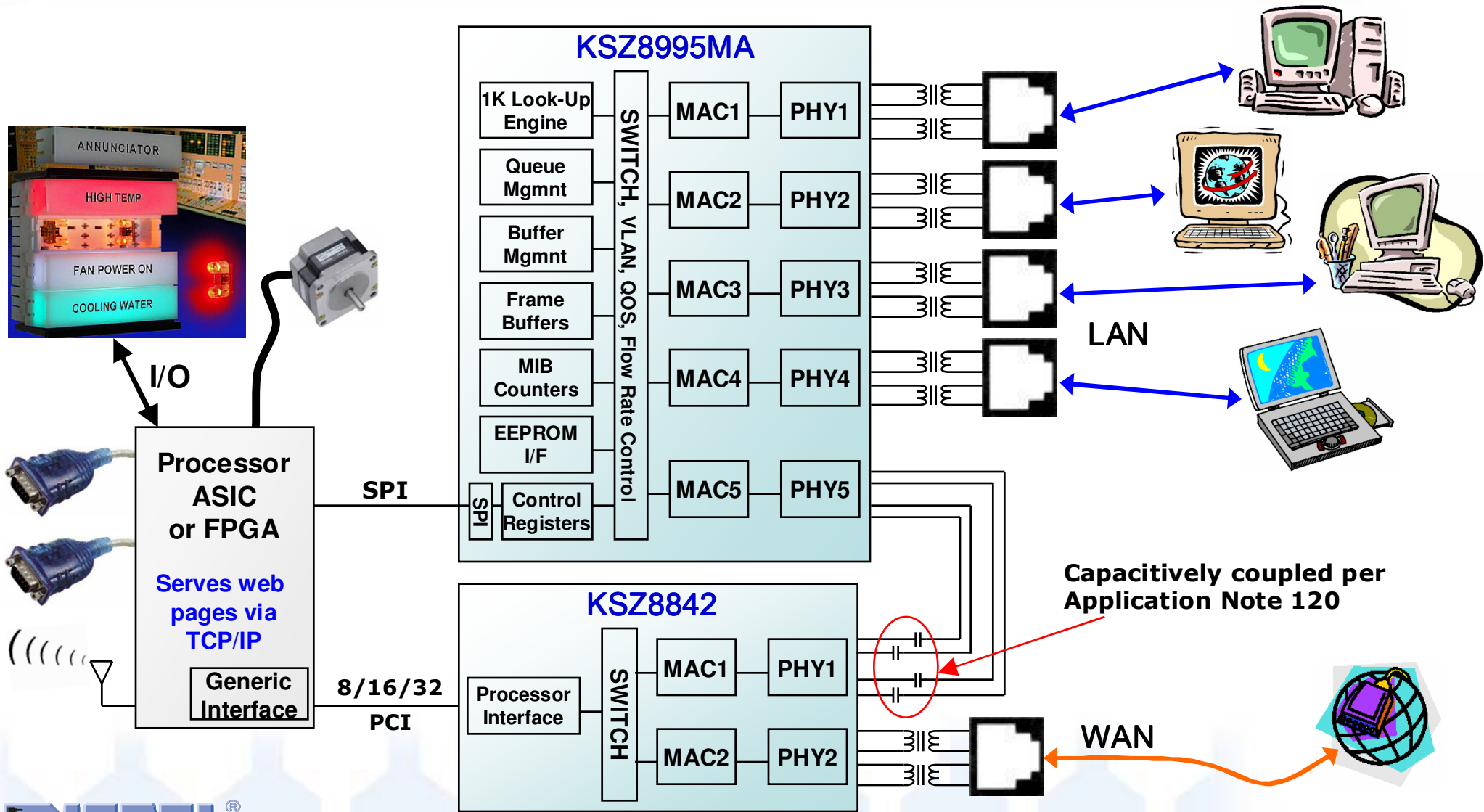

# Media Converters

## Simple Media Converter "Back-to-Back" PHY's

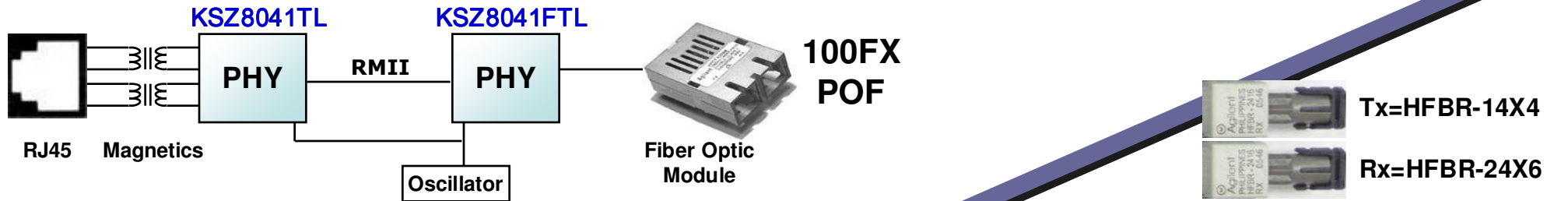

Standard	Reach	Fiber Diameter/Type	Wave-length
10Base-FL	2Km	62.5/125um Multi-Mode	850nm
100Base-SX	300m	50/125um MM optional	
100Base-FX	2Km	62.5/125um Multi-Mode	1300nm
POF(Passive Optical Fiber)	100m	980nm (Lowest Cost)	650nm

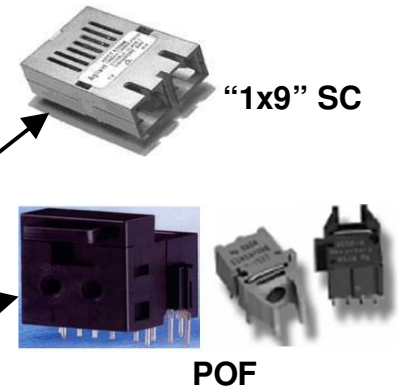

## Managed Media Converter

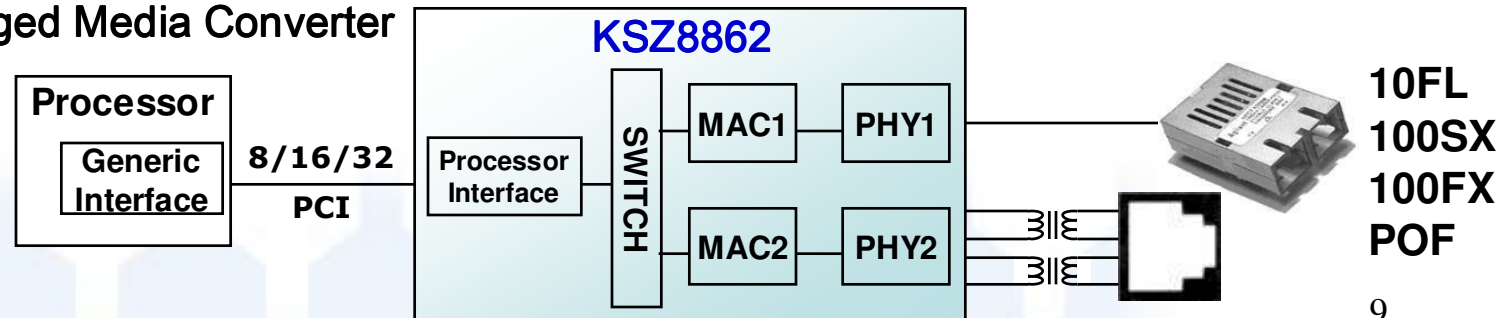

# Ethernet Connected to ANY Processor

## Traditional One Port Configuration

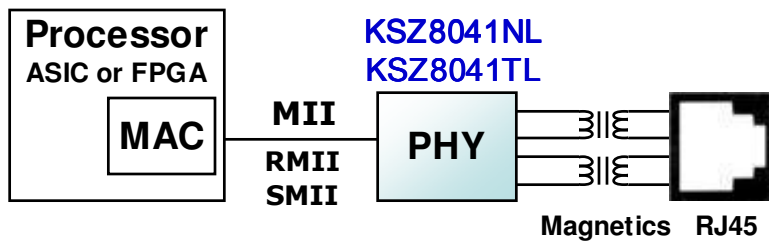

Ethernet packets pass through Switch and drop to processor only when intended for processor.

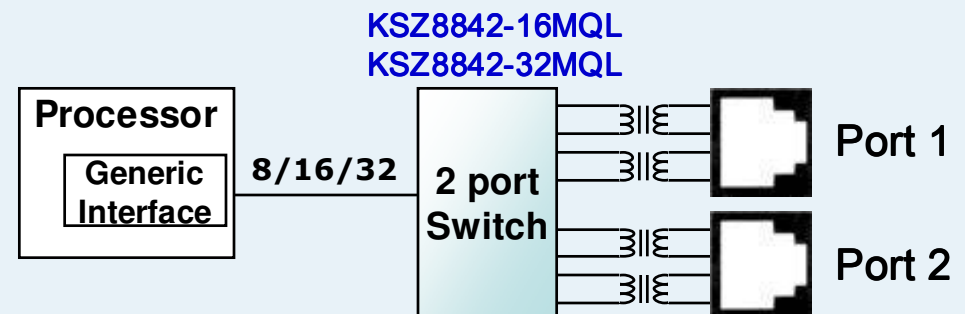
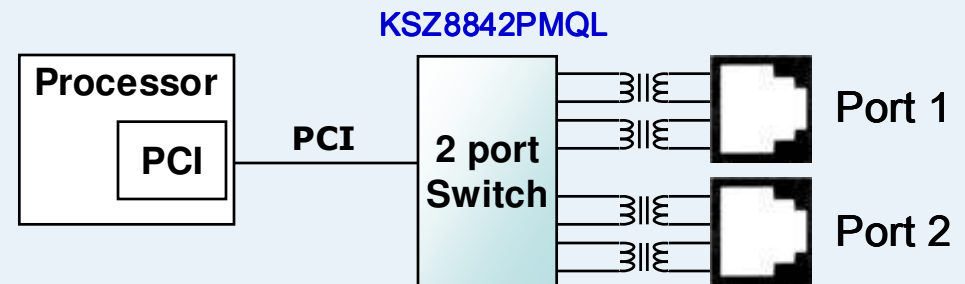
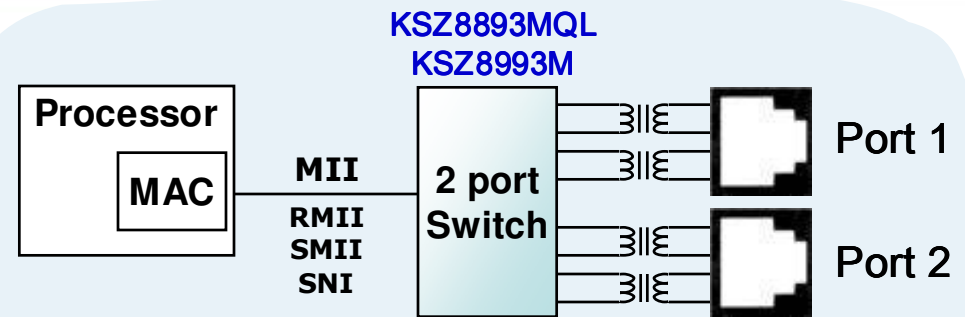

# Typical Applications

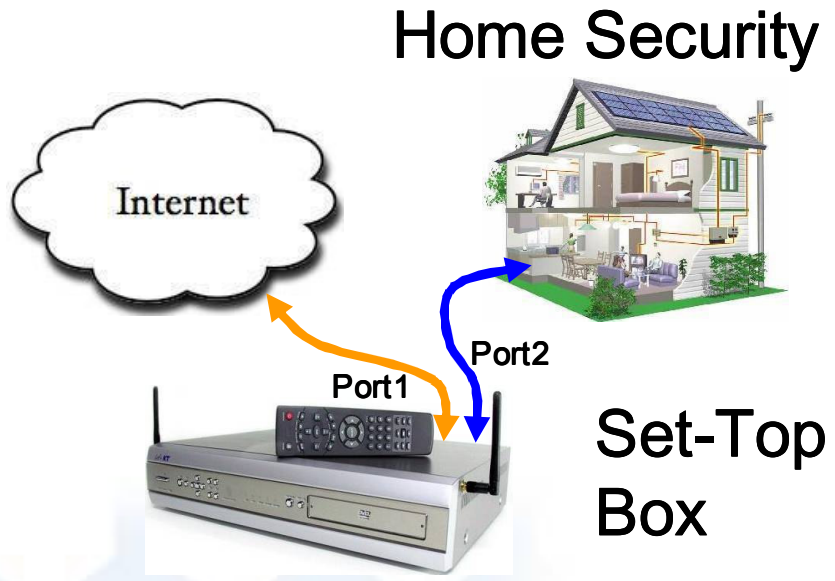
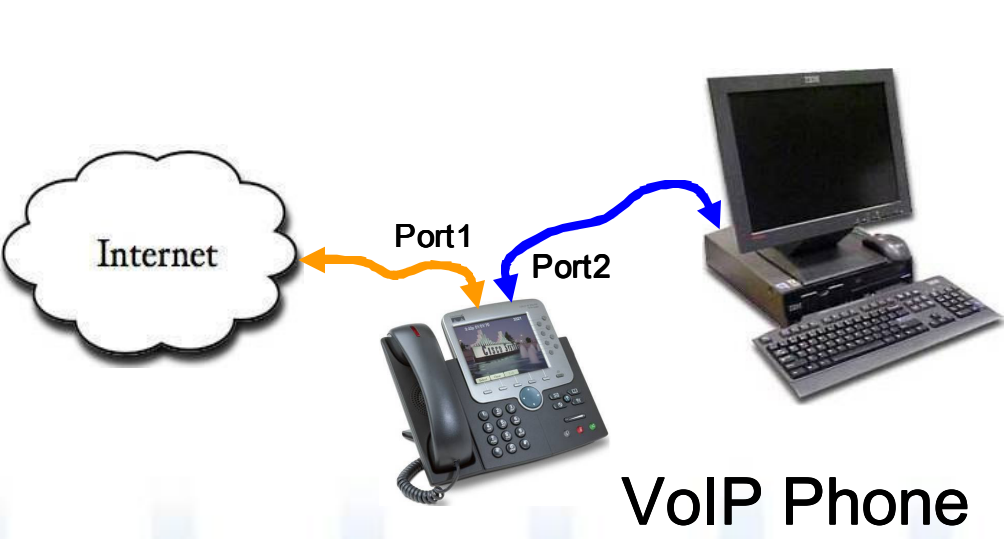
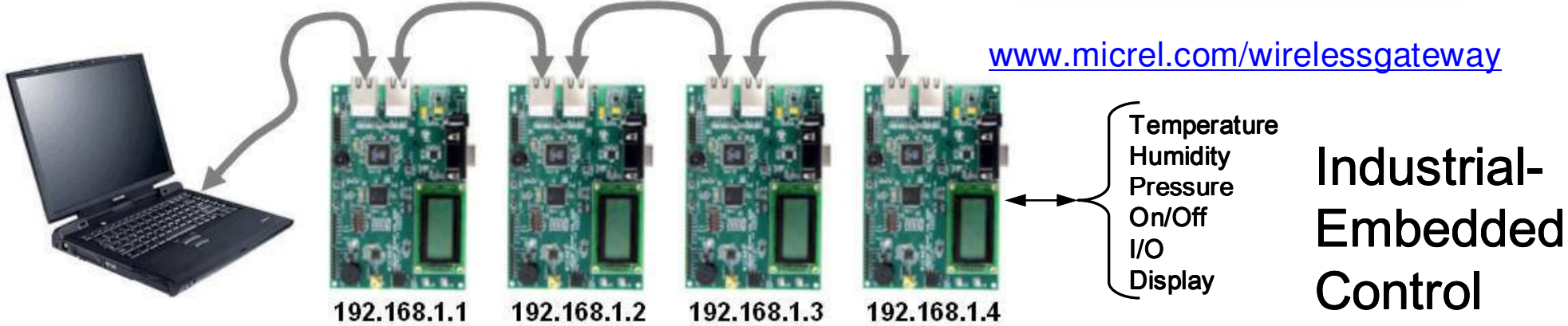

# 8-Bit Asynchronous Bus 8051 Example

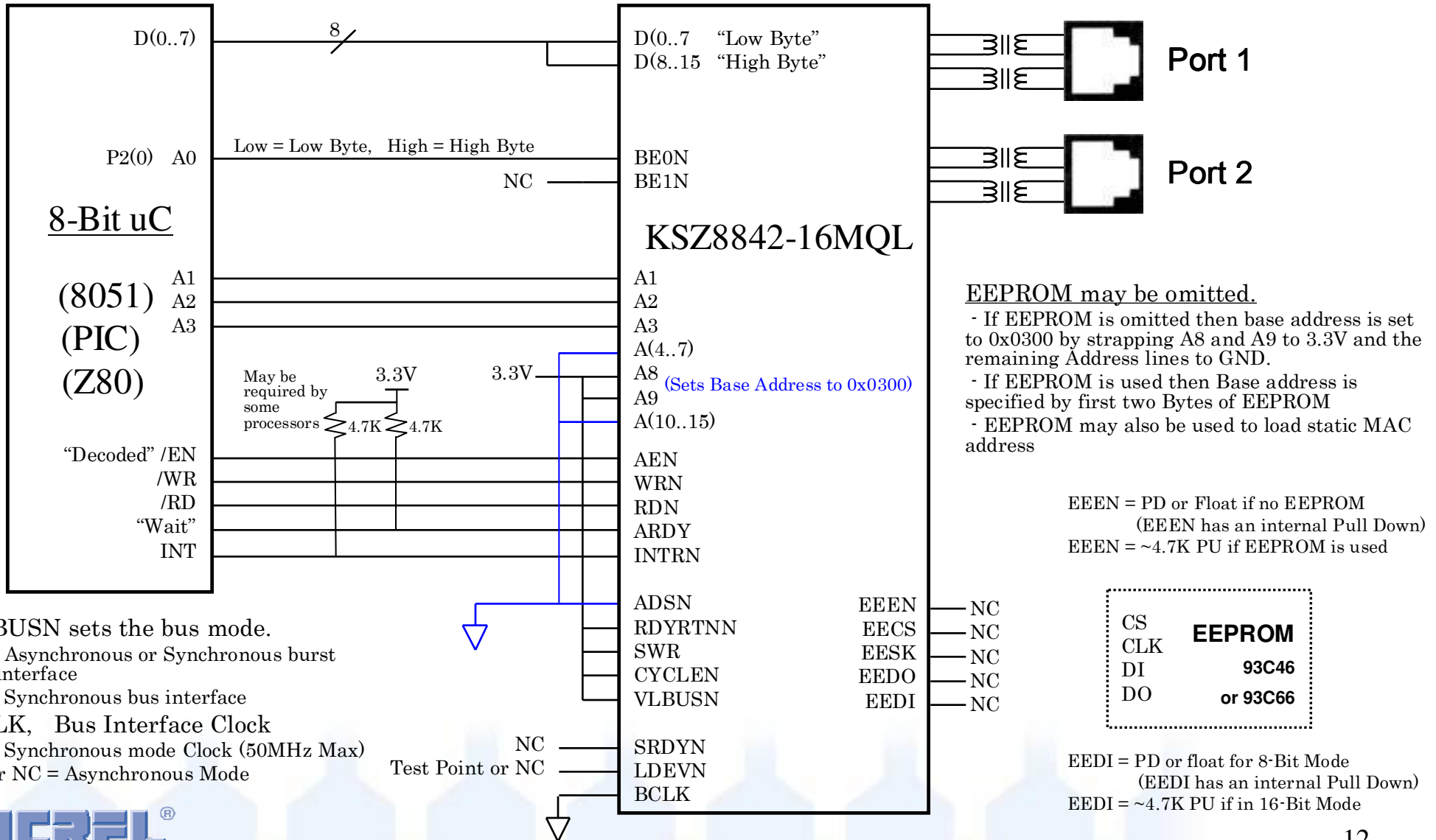

VLBUSN sets the bus mode.

1 = Asynchronous or Synchronous burst bus interface

0 = Synchronous bus interface

BCLK, Bus Interface Clock

1 = Synchronous mode Clock (50MHz Max)

0 or NC = Asynchronous Mode

# Micrel KSZ8695PX ARM based SOC

The KSZ8695PX provides a highly integrated Residential Gateway Solution.

Micrel provides Linux Source code for this application, see KSZ8695PX Design Kit.

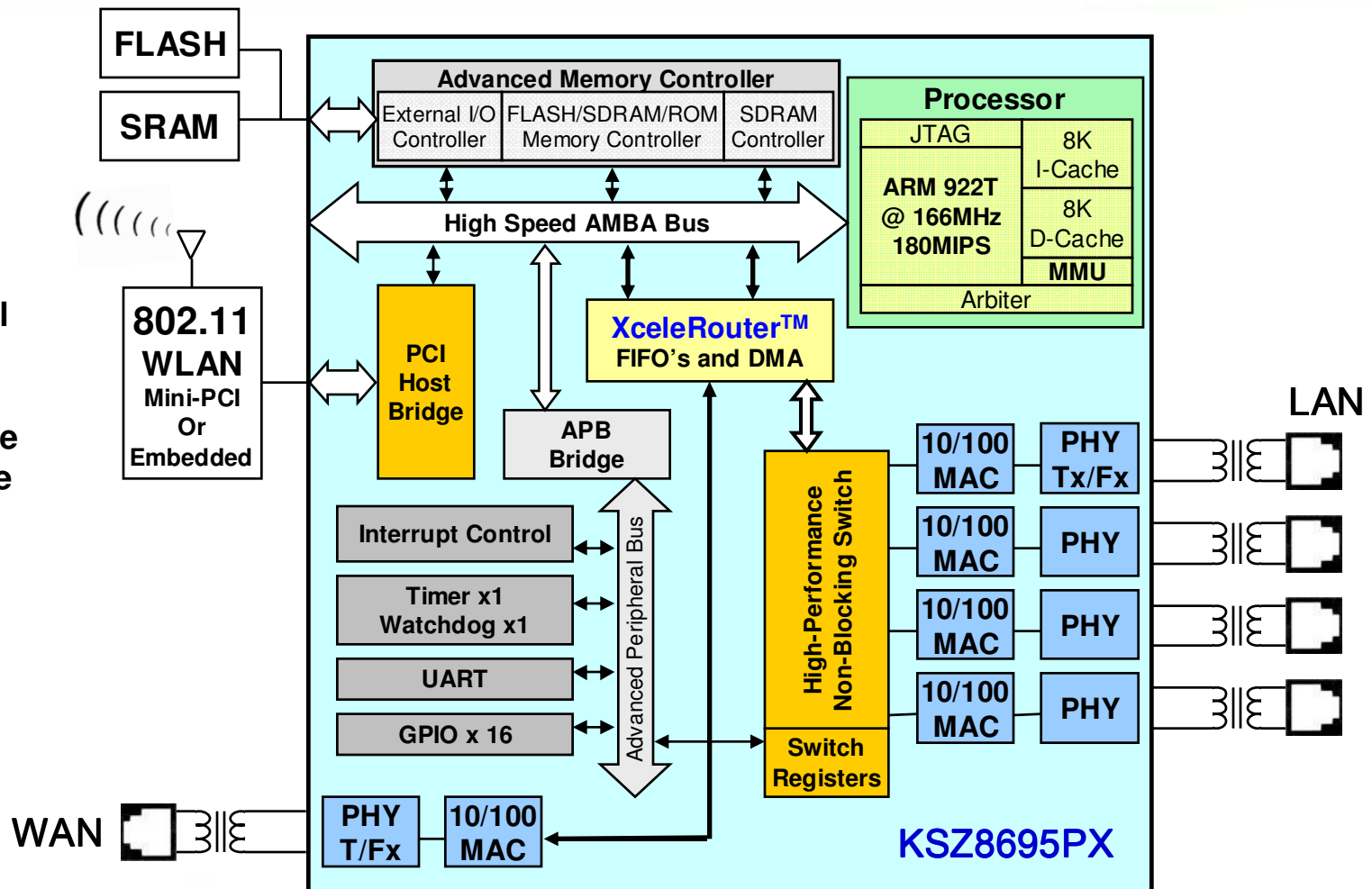

# KSZ8695PX as Industrial Controller

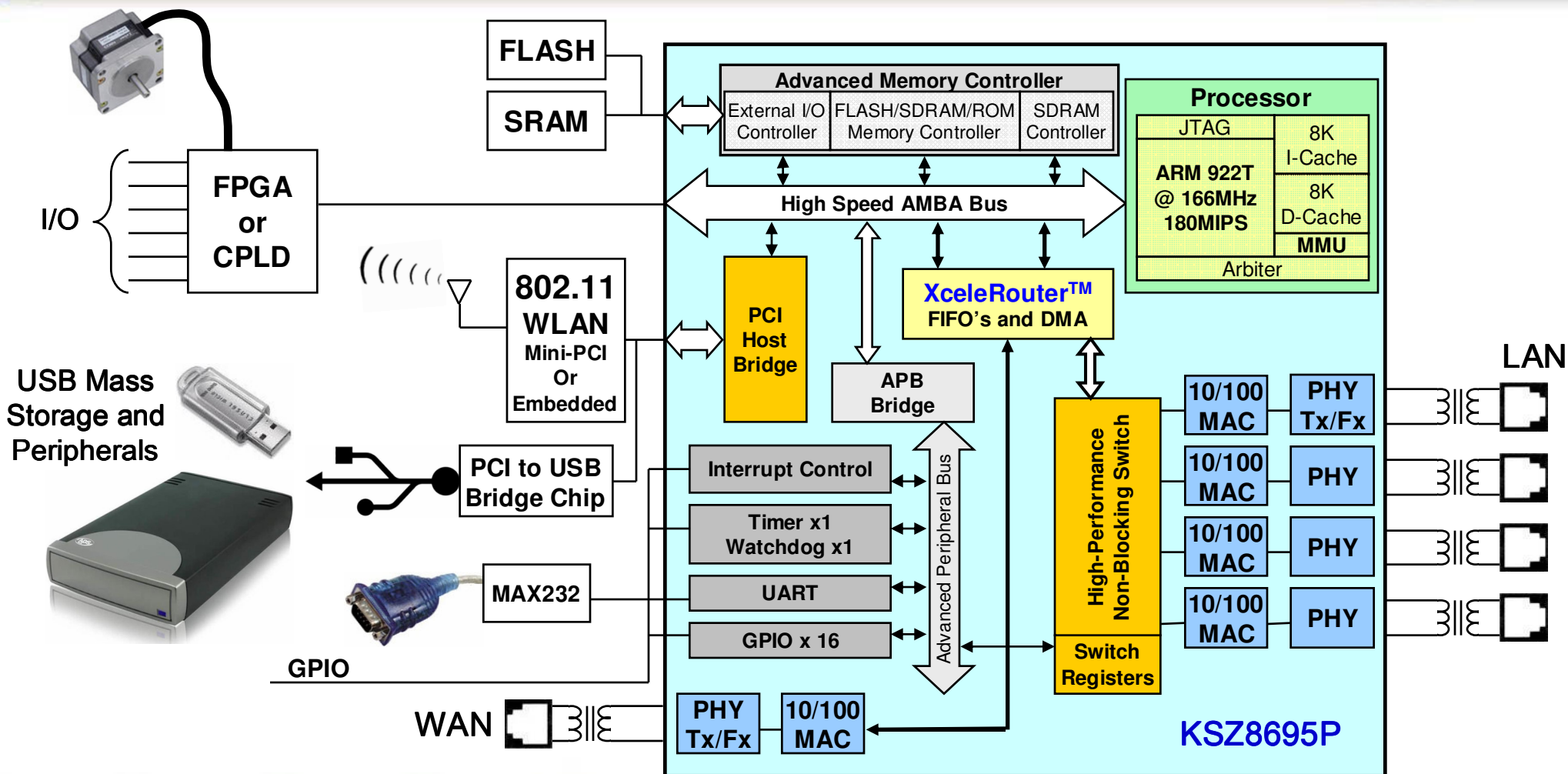

The KSZ8695P supports 3 masters on the PCI bus. Onboard Arbiter determines PCI bus ownership among PCI Master devices.